



## UTPB – Valet and Driveway Reno

**UTPB - VALET AND DRIVEWAY RENOVATION**  
6410 Fannin Street/ Houston, Texas 77030

**Date:** December 16, 2019  
**Johnston Project No.:** 19-00032-00  
**Prepared by:** Paula Gaviria

### Notice to General Contractor:

- A. Receipt of this Addendum shall acknowledge revisions to Contract Documents for above referenced project.
- B. This Addendum forms part of the Contract documents for the above referenced project and shall be incorporated integrally there with.
- C. Where provisions of the following supplemental data differ from those of the original Contract Documents, this Addendum shall govern.

### DOCUMENTS ATTACHED:

1. This Addendum addresses architectural, mechanical and electrical revisions as noted below, per comments from EH&S:

### REVISED DRAWINGS ISSUED

#### GENERAL

1. G0.00: COVER
  - Revised the name of the issue.
2. G0.01: DRAWING SHEET INDEX
  - Added Addendum #01 column and checked the sheets that are being issued.
3. G1.00: LIFE SAFETY PLAN
  - Revised existing and new fire tapes as smoke partitions.

#### ARCHITECTURAL

1. A1.01: OVERALL FLOOR PLAN
  - Revised existing and new fire tapes as smoke partitions.
2. A3.01: ENLARGED FLOOR PLAN & REFLECTED CEILING PLAN – INTERIOR
  - Revised existing and new fire tapes as smoke partitions.
  - Revised wall types to be smoke partitions.
  - Added exit sign to Corridor 103.
  - Added Fire Rated Legend to sheet.
  - Added a smoke detector in Pharmacy
  - Added and relocated fire strobes.
3. A10.04: PARTITION TYPES
  - Added wall type SA to sheet.
  - Removed wall type 1A from sheet.
4. A11.01: OPENING SCHEDULE
  - Revised door 105.1 and 106.1 fire rating.



## UTPB – Valet and Driveway Reno

### MECHANICAL

1. M0.01: MECHANICAL SCHEDULES, CONTROLS, AND DETAILS
  - Replaced detail for smoke dampers.
2. M2.01: MECHANICAL DUCTWORK PLAN – LEVEL 1
  - Revised keynote number 12 referring to smoke damper installation.

### ELECTRICAL

1. E1.01: ELECTRICAL SITE PLAN
  - Revised keynote L03 referring to existing lights
2. E2.01: ELECTRICAL LIGHTING PLAN – LEVEL 1
  - Revised emergency lighting in Waiting Room and Valet Office.
  - Added exit sign to Corridor.
3. E3.01: ELECTRICAL POWER PLAN – LEVEL 1
  - Added outlets to Corridor and Valet Office.
4. E5.01: ELECTRICAL FIRE ALARM PLAN – LEVEL 1
  - Added fire alarm pull string to Waiting Room.
  - Added and relocated fire strobes.
  - Added a smoke detector to Pharmacy.

**END OF UTPB - VALET AND Driveway  
RENOVATION -**



# UT HEALTH SYSTEM UTPB - VALET & DRIVEWAY RENOVATION

DATE ISSUED:  
2019 12 16

## UTPB - VALET & DRIVEWAY RENOVATION

PROJECT NO. : 19-00032-00

6410 FANNIN ST.  
HOUSTON, TX 77030

### CONSULTANTS:

**MEP**  
**JOHNSTON, LLC**  
2603 AUGUSTA DR., SUITE 1500  
HOUSTON, TX 77057

**CIVIL & STRUCTURAL**  
**WALTER P MOORE**  
1301 MCKINNEY, SUITE 1100  
HOUSTON, TX 77010

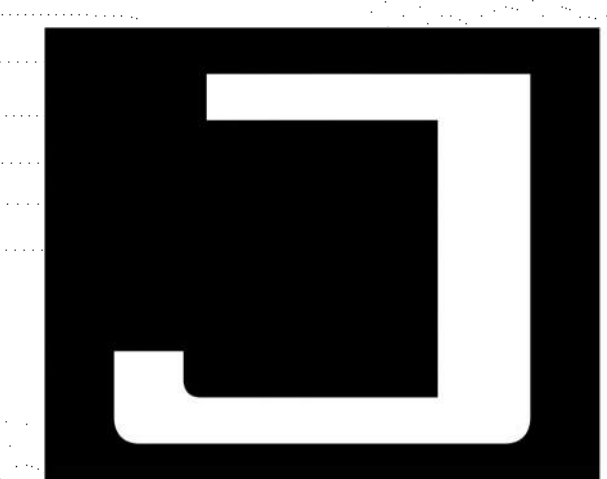
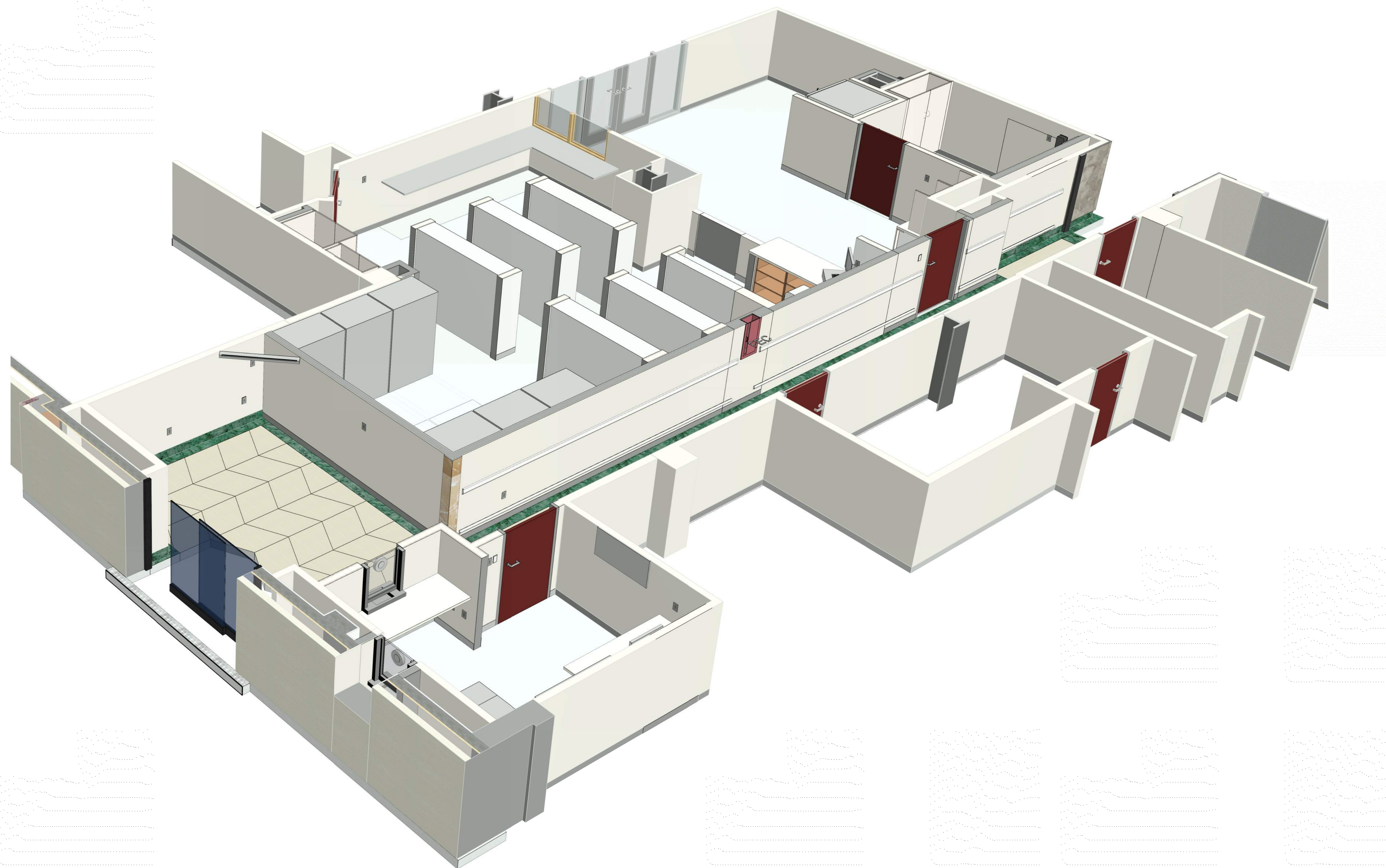

**JOHNSTON**

2603 Augusta Drive  
Suite 1500  
Houston, Texas 77057  
713.244.8300  
[www.johnstonllc.com](http://www.johnstonllc.com)



ARCHITECTURAL / INTERIORS ABBREVIATIONS

Table of architectural and interior abbreviations including items like AB (Anchor Bolt), AC (Accessories), ACCOUS (Acoustic), AD (Area Drain), ADA (Americans with Disabilities Act), etc.

GENERAL NOTES

- A. GENERAL NOTES: 1. THE CONTRACTOR SHALL PROVIDE COMPLETE PROJECT SYSTEMS AND COMPONENTS AND COMPLY WITH ALL REQUIREMENTS INDICATED ON THE PROJECT DOCUMENTS. 2. WORK WITHIN THE AREA BOUNDARIES INDICATED IN THE PROJECT DOCUMENTS...

PROJECT INFORMATION

PROJECT ADDRESS: UNIVERSITY OF TEXAS PROFESSIONAL BUILDING 6410 FANNIN STREET HOUSTON, TX 77057
PROJECT DESCRIPTION: THIS 9,649 S.F. PROJECT INCLUDES: 1. RENOVATION OF DRIVEWAY BETWEEN THE UT HEALTH PROFESSIONAL BUILDING AND PARKING GARAGE TO REPAIR PLUMBING, UPDATE PEDESTRIAN ROUTE AND ADD FLOOD PREVENTION IMPROVEMENTS.

LOCATION MAP

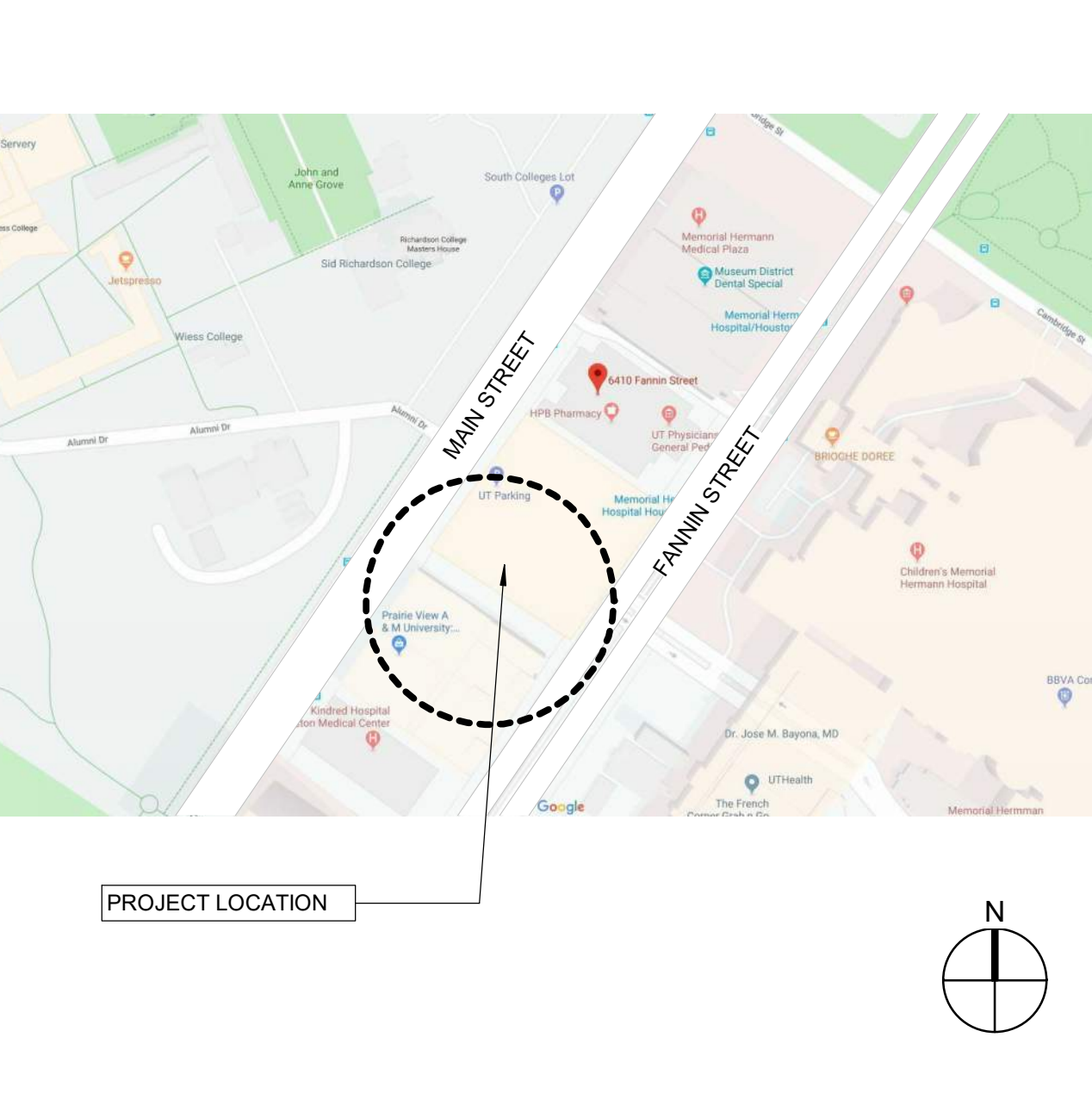

ANNOTATION SYMBOLS

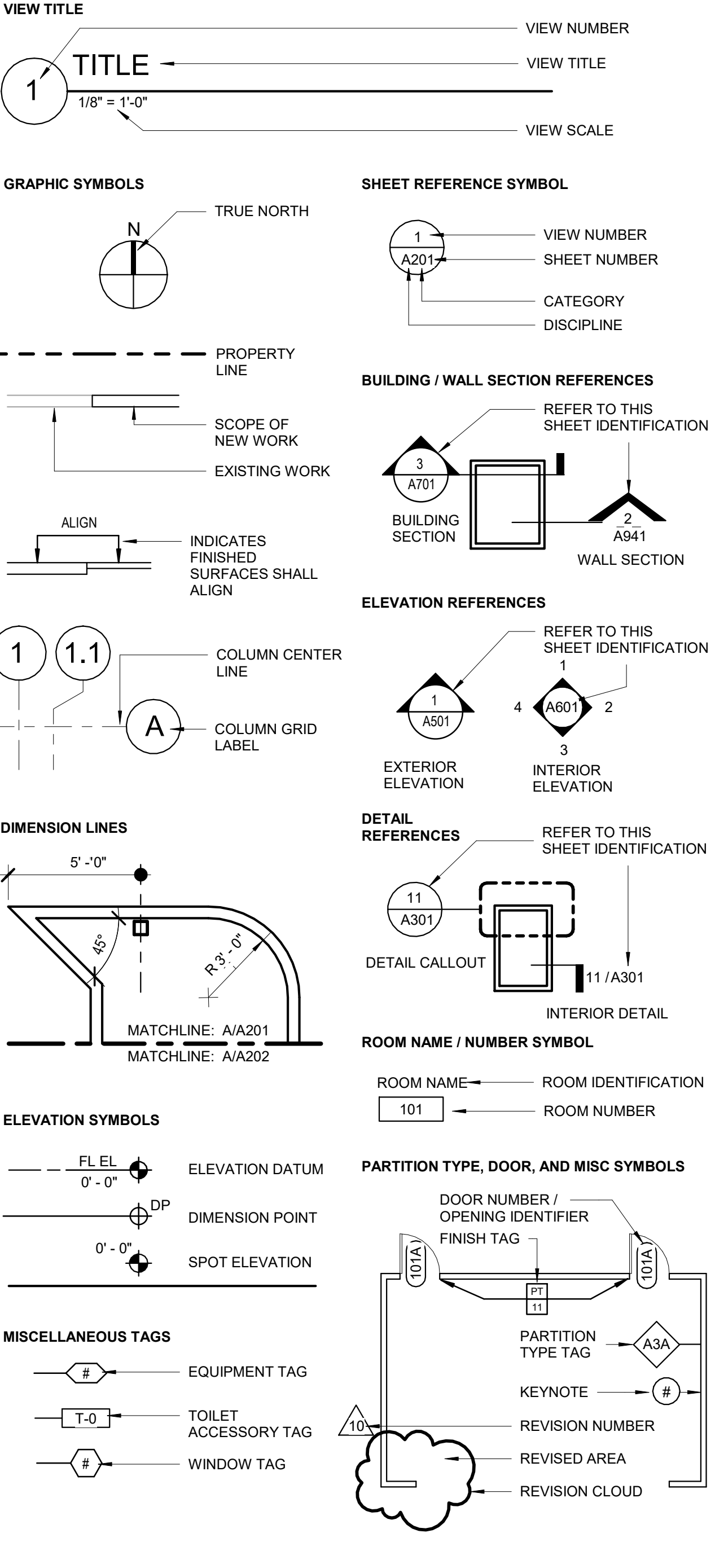

PROJECT TEAM

ARCHITECT: Johnston, LLC 2603 Augusta Dr., Suite 1500 Houston, TX 77057
MVP ENGINEER: Johnston, LLC 2603 Augusta Dr., Suite 1500 Houston, TX 77057
CIVIL & STRUCTURAL ENGINEER: WALTER P MOORE 1301 MCKINNEY, SUITE 1500 HOUSTON, TX 77010

KEY MAP

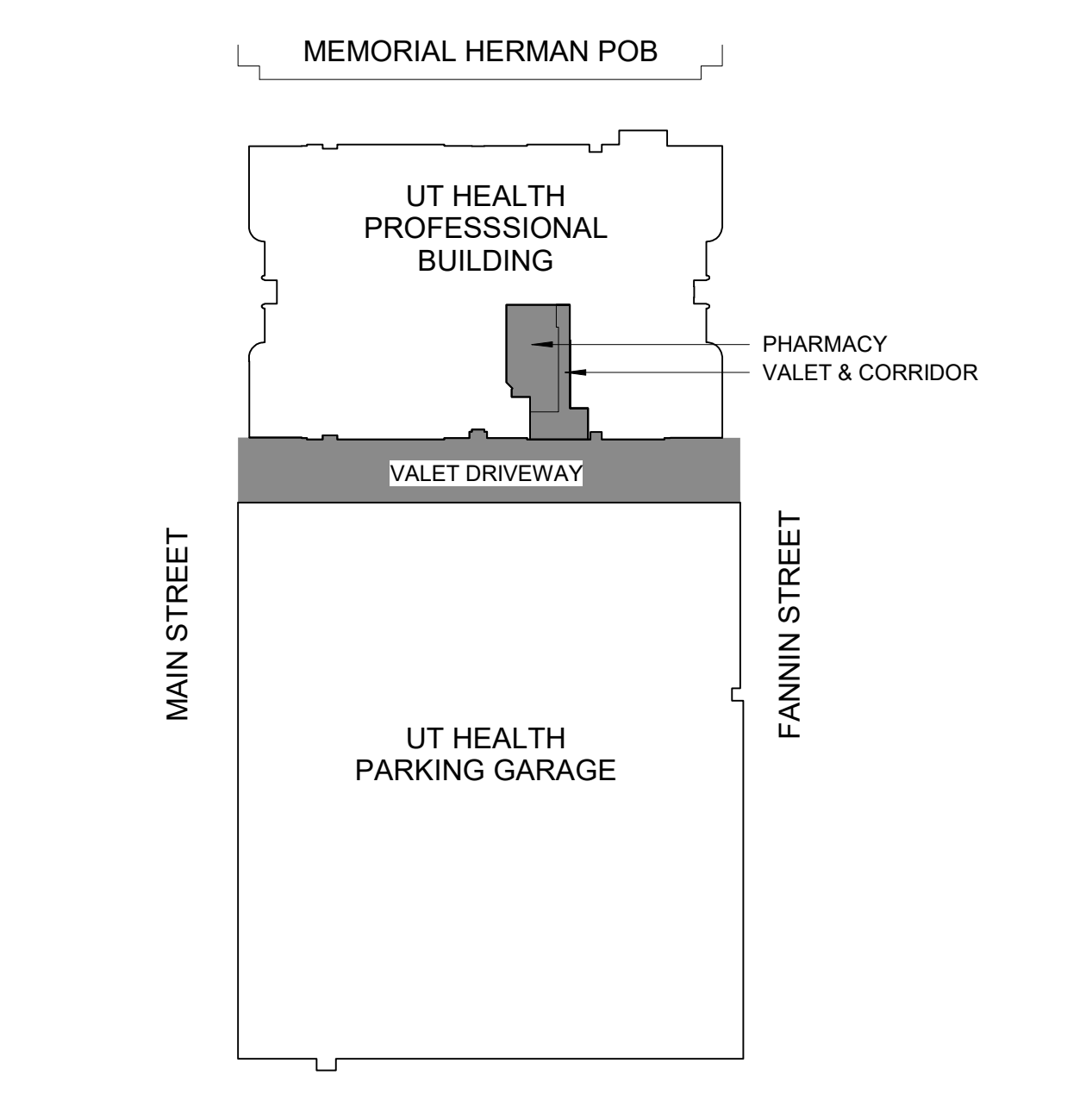

DRAWING INDEX

Drawing Index table listing sheets by discipline (General, Civil, Structural, Demolition, Architectural, Interiors, Mechanical, Plumbing, Electrical) and their titles, such as G0.00 COVER, C0.02 TOPOGRAPHIC SURVEY, S0.01 GENERAL NOTES, etc.

CODE SUMMARY

Code Summary table listing project address (UT Health Professional Building), owner (UT Health Systems), applicable codes and ordinances (NFPA 101, International Building Code, etc.), and fire-resistive construction requirements.

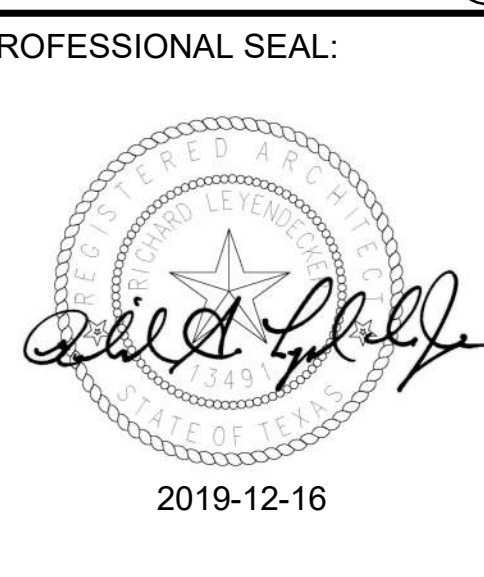
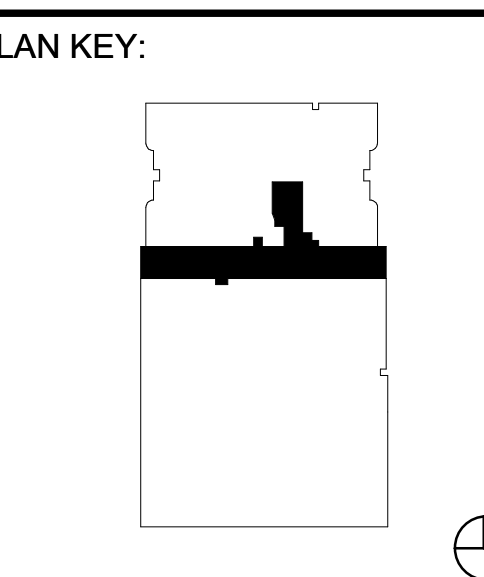
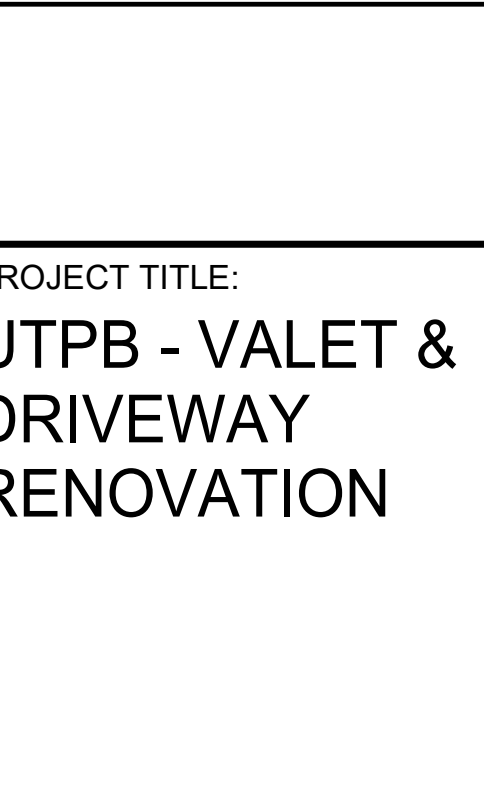
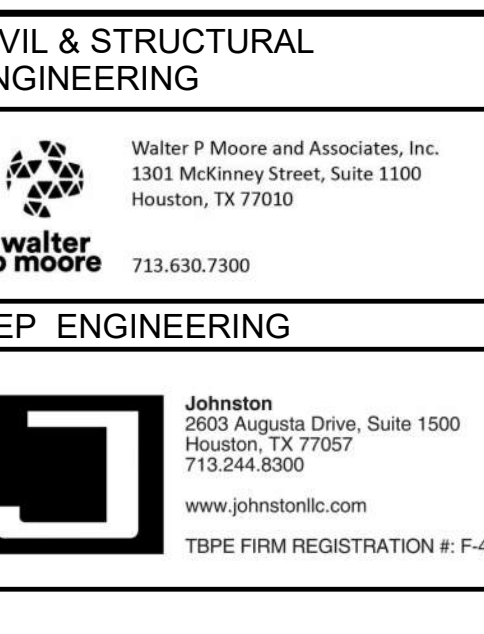

Table with project submission information: PROJECT NO. 19-00032-00, DRAWN BY JOHNSTON, SHEET TITLE GENERAL NOTES, ABBREVIATIONS, SYMBOLS, INDEX, AND CODE SUMMARY.

SHEET: G0.01



**LIFE SAFETY GENERAL NOTES**

- A. EXISTING CONSTRUCTION FULLY SPRINKLERED.
- B. NO MODIFICATIONS TO FIRE RATED WALLS ARE INCLUDED IN THE SCOPE OF THIS PROJECT.
- C. NO MODIFICATIONS TO THE OCCUPANT LOAD ARE INCLUDED IN THE SCOPE OF THE PROJECT.
- D. NO MODIFICATIONS TO SMOKE COMPARTMENT ARE INCLUDED IN THE SCOPE OF THE PROJECT.

**LIFE SAFETY SYMBOLS LEGEND**

- EXISTING CONSTRUCTION
- EXIT
- 1-HOUR MIN FIRE-RESISTANCE RATED FIRE BARRIER  
45 MIN OPENING PROTECTIVE
- 2-HOUR MIN FIRE-RESISTANCE RATED FIRE BARRIER  
90 MIN OPENING PROTECTIVE
- SMOKE PARTITION
- 1-HOUR SMOKE BARRIER WALL  
45 MIN OPENING PROTECTIVE
- 2-HOUR FIRE/SMOKE WALL  
90 MIN OPENING PROTECTIVE
- FIRE EXTINGUISHER

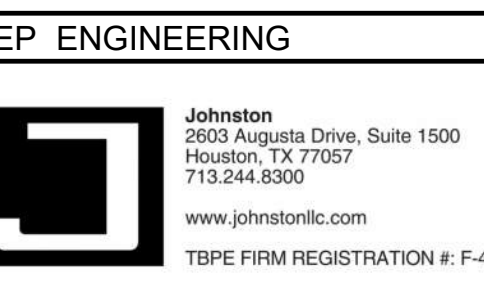
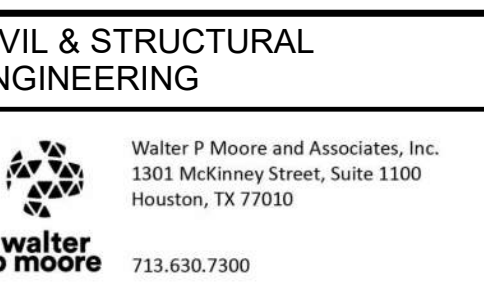

PROJECT TITLE:  
**UTPB - VALET &  
DRIVEWAY  
RENOVATION**

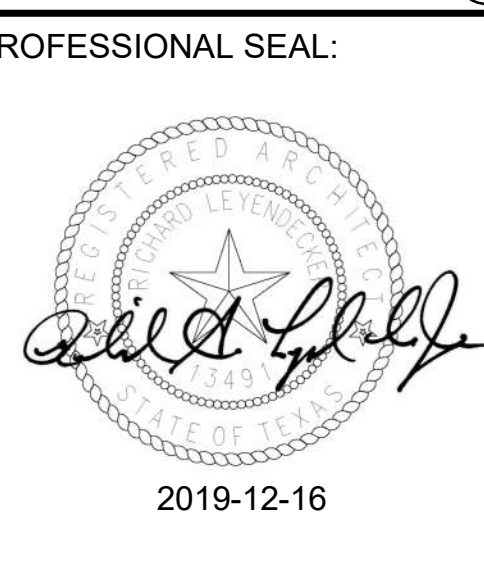
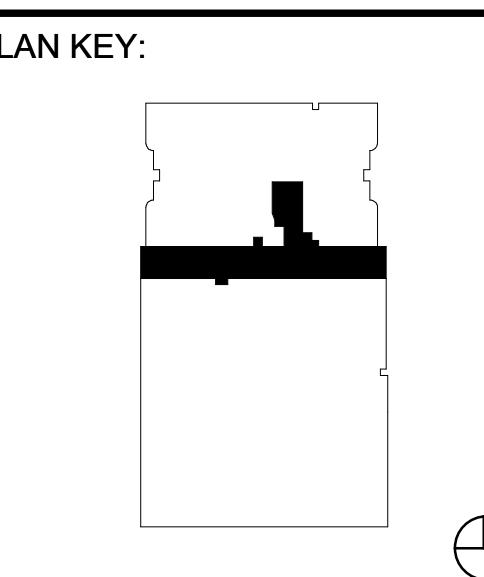

PROJECT SUBMISSION:  
**ADDENDUM #01**

DATE: 2019-12-16

NO.	REVISION/ISSUE	YYYY MM DD
1	ADDENDUM #01	2019 12 16

PROJECT NO: 19-00032-00  
DRAWN BY: JOHNSTON  
SHEET TITLE:  
**LIFE SAFETY PLAN**

SHEET:  
**G1.00**

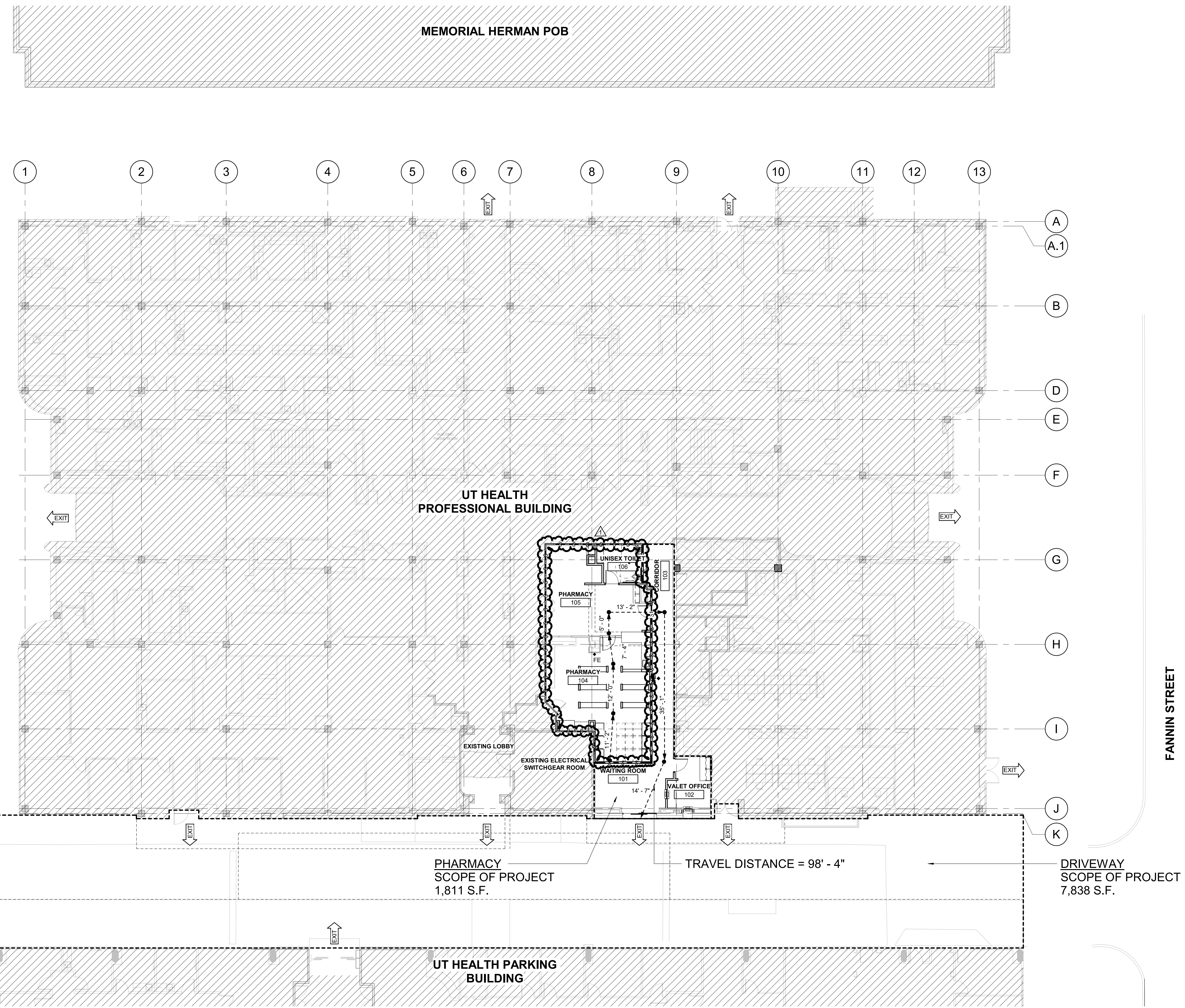

**NOTE:** FIELD VERIFY ALL EXISTING CONDITIONS & DIMENSIONS PRIOR TO BEGINNING OF WORK



GENERAL NOTES - FLOOR PLAN

- A SHADED AREA DENOTES AREAS OUTSIDE OF THE LIMITS OF THE PROJECT SCOPE. CONTRACTOR TO COORDINATE WITH OWNER REGARDING DEMOLITION & CONSTRUCTION OUTSIDE OF THE PROJECT SCOPE AREA. ANY WORK DONE OUTSIDE THE PROJECT SCOPE SHOULD BE PATCHED/CONSTRUCTED TO MATCH ADJACENT AREA.
- B THE GENERAL CONTRACTOR IS RESPONSIBLE FOR BRACING AND BLOCKING OF WALLS RECEIVING MILLWORK, SHELVING, EQUIPMENT, ETC. ALL WOOD BLOCKING, GROUNDS, ROUGH BUCKS, AND MISCELLANEOUS BLOCKING IS TO BE FIRE-RETARDANT TREATED.
- C THE GENERAL CONTRACTOR SHALL PATCH AND FINISH TO MATCH EXISTING ANY ADJACENT WALLS, FINISHES, ETC., AFFECTED IN ANY MANNER, BY CONSTRUCTION.
- D THE GENERAL CONTRACTOR SHALL FILL AND PATCH ALL OPENINGS AND HOLES LEFT AFTER DEMOLITION, SEAL AROUND ALL PIPING, DUCTS, ETC., AND ENSURE ACCORDANCE WITH APPLICABLE CODES AND ORDINANCES. RE: SHEET A10.05 FOR SEALING PENETRATIONS.
- E THE GENERAL CONTRACTOR IS TO NOTIFY ARCHITECT IF FLOOR PENETRATIONS CONFLICT WITH STRUCTURAL ELEMENTS, DUCTWORK, ETC., PRIOR TO PROCEEDING WITH WORK.
- F PARTITIONS:
  - F1 DO NOT SCALE DRAWINGS, DIMENSIONS GOVERNING. DIMENSIONS ARE TO FACE OF FINISHED PARTITION U.N.O. (GYPSUM BOARD SURFACE-NOT STUD).
  - F2 PARTITIONS THAT ALIGN WITH EXISTING BUILDING PARTITIONS SHALL ALIGN WITH FINISHED FACE OF NEW GYPSUM LAYER.
  - F3 GYPSUM BOARD ABOVE CEILING TO BE TAPED AND FLOATED ONLY.
  - F4 INSTALL 5/8" WATER RESISTANT GYPSUM BOARD AT ALL PLUMBING CHASES.
  - F5 REFER TO SHEET A10.04 FOR PARTITION TYPES.
  - F6 PROVIDE BRACING ABOVE CEILING HEIGHT PARTITIONS WHEN LONG UNBRACED WALL LENGTHS OCCUR, AND AT ALL DOOR AND GLAZED OPENING JAMBS IN ACCORDANCE WITH MANUFACTURER'S SPECIFICATIONS.
  - F7 ALL PARTITIONS TO BE A3A, U.N.O.
- G THE GENERAL CONTRACTOR SHALL CONFIRM ALL OWNER FURNISHED, OWNER INSTALLED (O.F.O.I.) AND OWNER FURNISHED, CONTRACTOR INSTALLED (O.F.C.I.) ITEMS WITH THE ARCHITECT AND THE OWNER PRIOR TO CONSTRUCTION, TO CONFIRM ALL DIMENSIONAL, ARCHITECTURAL, AND MEP REQUIREMENTS AS CONFIGURED IN THESE DOCUMENTS.
- H REFERENCE IDENTIFICATION OF DOORS IS SCHEDULED BY THE CORRESPONDING ROOM NUMBER IN WHICH THE OPENING OCCURS OR GIVES ACCESS TO. REFER TO A11.01 FOR DOOR SCHEDULE.
- I PROVIDE BLOCKING FOR ALL WALL MOUNTED EQUIPMENT.
- J FOR TYPICAL MOUNTING HEIGHTS REFER TO G2.00.
- K EXISTING TO REMAIN RATE TO CONCRETE FLOOR. SEAL ALL HOLES CAUSED BY THE REMOVAL OF PIPES, CONDUITS, DUCTS, ETC. SEAL OPENINGS IN BARRIERS W/ APPROVED FIRE RATED MATERIAL.
- L FOR ROOM FINISHES REFER TO "FINISH SCHEDULE" & FINISH PLANS ON IF0.00.
- M CLOSE ALL JOINTS BETWEEN PLUMBING FIXTURES, ACCESSORIES & DISSIMILAR MATERIALS W/ SEALANT (I.E. SINKS & ACCESSORIES TO WALL)
- N REFER TO MEP DRAWINGS FOR MED GASES LOCATION, RECESSED ALARM PANDS, VALVE BOXES & ELECTRICAL PANELS, U.N.O.
- O REFER TO SHEET A11.01 FOR WINDOW SCHEDULE
- P WALL MOUNTED GRAB BARS, GRAB BAR FASTENERS AND MOUNTING DEVICES TO SUPPORT AT LEAST 250 LBS. SEE ELEVATION FOR MOUNTING LOCATION AND REFER TO STRUCTURAL DRAWINGS FOR MOUNTING REQUIREMENTS.



CIVIL & STRUCTURAL ENGINEERING

Walter P Moore and Associates, Inc.  
1303 McKinney Street, Suite 1100  
Houston, TX 77002  
www.walterpmoore.com  
713.630.7300

MEP ENGINEERING

Johnston  
2803 Augusta Drive, Suite 1500  
Houston, TX 77057  
713.244.8300  
www.johnstonllc.com  
TYPE FIRM REGISTRATION # F-421

PROJECT TITLE:  
**UTPB - VALET & DRIVEWAY RENOVATION**

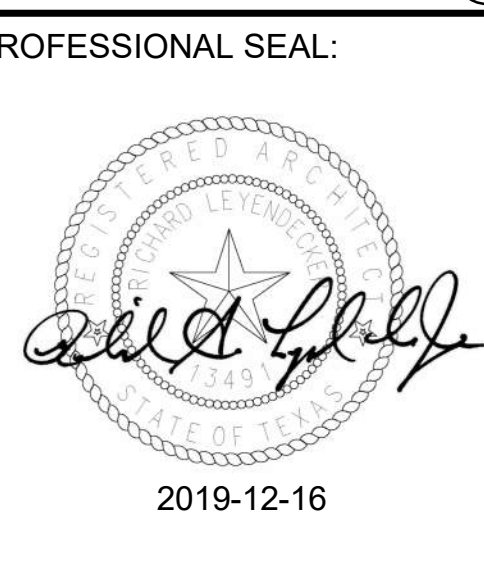
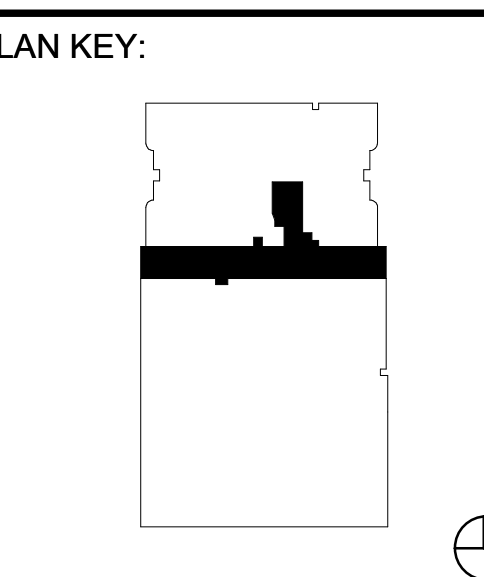

PROJECT SUBMISSION:  
**ADDENDUM #01**

DATE: 2019-12-16

NO.	REVISION/ISSUE	YYYY MM DD
1	ADDENDUM #01	2019 12 16

PROJECT NO: 19-00032-00  
DRAWN BY: JOHNSTON

SHEET TITLE:  
**OVERALL FLOOR PLAN**

SHEET:  
**A1.01**

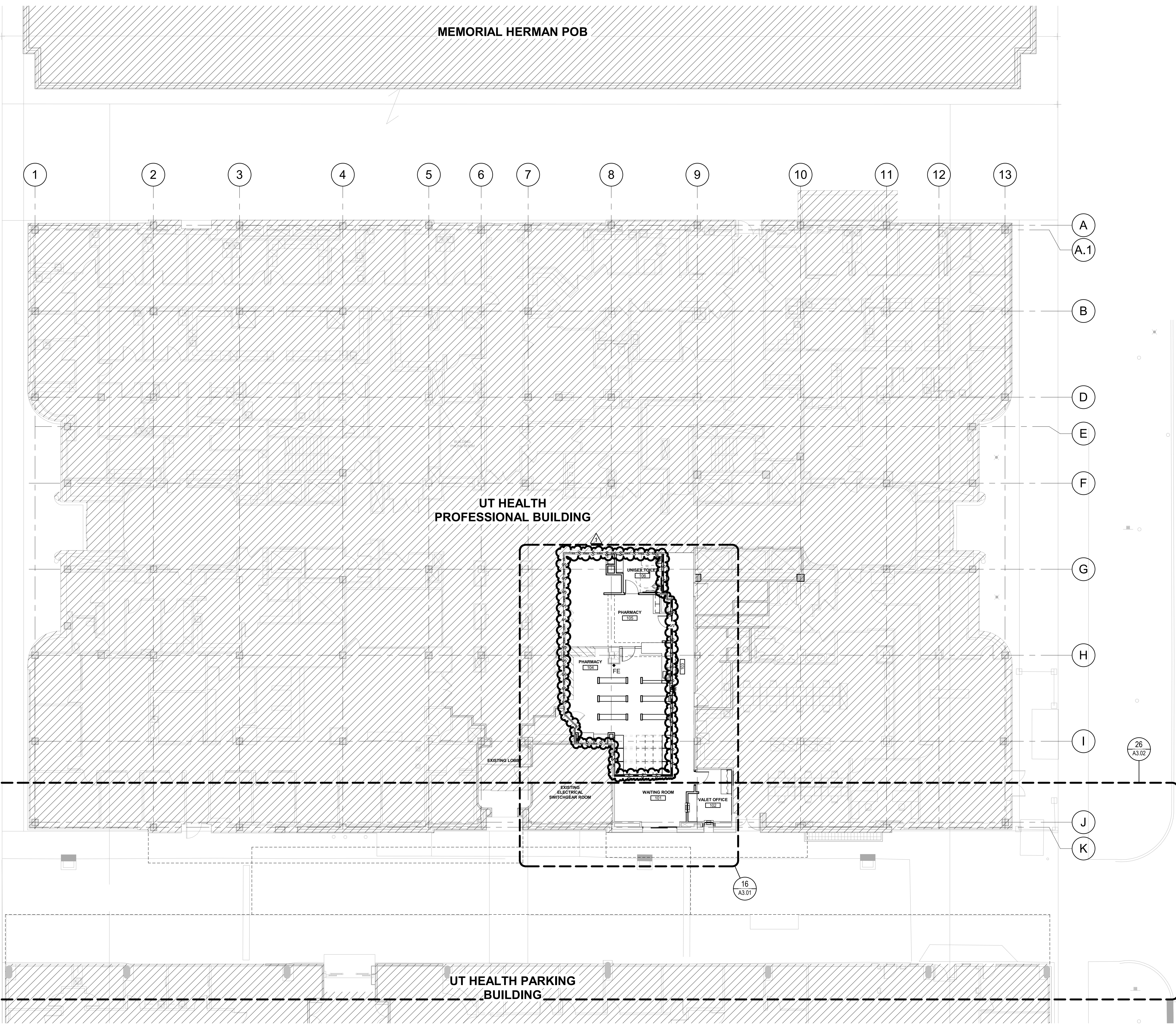

FLOOR PLAN LEGEND

- AREA NOT IN CONTRACT/EXISTING CONSTRUCTION TO REMAIN
- EXISTING PARTITION TO REMAIN
- NEW GYP BD PARTITION AS INDICATED
- NEW DOOR, DOOR IDENTIFIER ASSEMBLY AS INDICATED ON A11.01
- NEW FIRE EXTINGUISHER CABINET RE: A10.03
- NEW FIRE EXTINGUISHER RE: SPECIFICATIONS
- OPENING SCHEDULE RE: A11.01

FIRE RATING LEGEND

- 1-HOUR MIN FIRE-RESISTANCE RATED FIRE BARRIER 45 MIN OPENING PROTECTIVE
- 2-HOUR MIN FIRE-RESISTANCE RATED FIRE BARRIER 90 MIN OPENING PROTECTIVE
- SMOKE PARTITION
- 1-HOUR SMOKE BARRIER WALL 45 MIN OPENING PROTECTIVE
- 1-HOUR FIRE/SMOKE WALL 45 MIN OPENING PROTECTIVE
- 2-HOUR FIRE/SMOKE WALL 90 MIN OPENING PROTECTIVE

NOTE: FIELD VERIFY ALL EXISTING CONDITIONS & DIMENSIONS PRIOR TO BEGINNING OF WORK



**KEYNOTES LEGEND**

- 1 PROVIDE CEILING MOUNTED CAMERA RE: 10/A10.02 AND COORDINATE WITH OWNER.
- 2 RE: SHEET A10.02 FOR TYPICAL GYP BD CEILING DETAILS
- 3 EXISTING CEILING, LIGHTING FIXTURES AND ABOVE CEILING WORK TO REMAIN. PROTECT IN PLACE. PATCH AND MATCH EXISTING AS NECESSARY FOR RENOVATION. RE: MEP DRAWINGS
- 4 EXISTING COLUMN AND PIPES TO REMAIN. PROTECT AS REQUIRED.
- 5 EXISTING DRIVEWAY TO REMAIN RE: AD2.02
- 6 EXISTING MILLWORK TO REMAIN. PROTECT AS REQUIRED
- 7 EXISTING FURDOWN TO REMAIN.
- 8 WALL SCONCE MOUNTED AT 6'-6" A.F.F., RE: ELECTRICAL DRAWINGS
- 9 VANITY LIGHT, TYP. RE: ELECTRICAL DRAWINGS
- 10 RELOCATED EXISTING SHELVING
- 11 LOW WALL WITH SWING DOOR RE: ELEVATIONS AND A10.01

**KEYNOTES LEGEND**

- 12 SURFACE MOUNTED ENTRY MAT RE: FINISHES PLAN
- 13 RECESSED ENTRY MAT RE: FINISHES PLAN AND 11/A10.03
- 14 EXISTING CANOPY ABOVE (SHOWN DASHED)
- 15 PROVIDE BACKING/LOCKING IN WALL AS REQUIRED FOR WALL MOUNTED TV
- 16 FLOOR DRAIN, SLOPE TO DRAIN, RE: 01/A10.03 & PLUMBING DRAWINGS
- 17 PROVIDE BACKING IN WALL AS REQUIRED FOR UPPER CABINETS
- 18 RADIUS EDGE AT COUNTERTOP
- 19 EXISTING FURDOWN ABOVE
- 20 TRANSACTION WINDOW RE: 28/A11.01
- 21 FLOOR TRANSITION RE: 18/A10.03
- 22 TRANSITION/SILL DETAIL RE: 23/A11.02
- 23 PROVIDE ADDITIONAL SUPPORT AS REQUIRED IN PARTITION LENGTH OF GRAB BAR TO SUPPORT A MINIMUM WEIGHT OF 200 LBS.
- 24 PROVIDE ACCESS PANEL AS REQUIRED RE: 08/A10.02
- 25 PROVIDE FINISHED END PANEL SUPPORT
- 26 PROVIDE UNDER CABINET LIGHTING AT UPPER CABINET RE: ELECTRICAL DRAWINGS
- 27 NEW HIGH DENSITY STORAGE SYSTEM SHELVING HT. 86.5" A.F.F.
- 28 FIRE EXTINGUISHER CABINET RE: 03/A10.03
- 29 WALL MOUNTED FIRE EXTINGUISHER RE: SPECIFICATIONS
- 30 VERIFY COMPLIANCE OF EXIST. WALLS, DOORS, AND FRAMES WITH INDICATED RATING. UPGRADE AS NECESSARY.
- 31 SIZE OF COLUMN TO BE VERIFIED DURING CONSTRUCTION.

**FLOOR PLAN GENERAL NOTES**

REFER TO SHEET A1.01 FOR FLOOR PLAN GENERAL NOTES

**GENERAL NOTES - RCP**

- A REFER TO "FINISH SCHEDULE" FOR FURTHER DEFINITION OF CEILING MATERIALS AND FINISHES.
- B LOCATE ALL CEILING MOUNTED SMOKE DETECTORS AND SPEAKERS IN THE CENTER OF FULL PANELS AT LAY-IN CEILING.
- C LOCATE ALL SPRINKLER HEADS IN THE CENTER OF FULL PANELS AT LAY-IN CEILINGS. AT GYPSUM BOARD CEILINGS, SYMMETRICALLY SPACE HEADS AND CENTER ON LIGHT ROWS WHERE AREAS LIMITATIONS PERMIT.
- D REFER TO CEILING PLANS FOR CEILING HEIGHTS. ALL HEIGHTS ARE TO BOTTOM OF GRID SYSTEM OR GYP BOARD ABOVE FINISH FLOOR (AFF RELATIVE TO THE FLOOR THAT THE CEILING PLAN IS SHOWN).
- E REFER TO ELECTRICAL DRAWINGS FOR LIGHT FIXTURE TYPES.
- F ALL CEILING GRIDS ARE TO BE CENTERED IN A ROOM UNLESS DIMENSIONED OTHERWISE.
- G REFER TO MECHANICAL DRAWINGS FOR HVAC DIFFUSER GRILLE SIZES AND TYPES.
- H SHADED AREA DENOTES AREAS OUTSIDE OF THE LIMITS OF THE PROJECT SCOPE. CONTRACTOR TO COORDINATE WITH OWNER REGARDING DEMOLITION & CONSTRUCTION OUTSIDE OF THE PROJECT SCOPE AREA. ANY WORK DONE OUTSIDE THE PROJECT SCOPE SHOULD BE PATCHED/CONSTRUCTED TO MATCH ADJACENT AREA.
- I ALL CEILINGS TO BE 9'-0" AFF U.N.O. NEW TYPICAL CEILING HEIGHT TO MATCH EXISTING. VERIFY IN FIELD EXISTING CONDITION.
- J ALL ACOUSTICAL CEILINGS TO BE ACT-1, RE: IF0.00 UNLESS NOTED OTHERWISE
- K ALL UPPER CABINETS TO HAVE UNDERCOUNTER LIGHTING, U.N.O.
- L ALL GYPSUM FUR DOWNS ARE AT 7'-6" UNLESS NOTED OTHERWISE. PAINT ALL SIDES & SOFFITS OF FUR DOWN PT-1. FUR DOWN AT WAITING AREA TO BE PAINTED PT-1

**FLOOR PLAN LEGEND**

- AREA NOT IN CONTRACT/EXISTING CONSTRUCTION TO REMAIN
- EXISTING PARTITION TO REMAIN
- NEW GYP BD PARTITION AS INDICATED
- NEW DOOR, DOOR IDENTIFIER ASSEMBLY AS INDICATED ON A11.01
- NEW FIRE EXTINGUISHER CABINET RE: A10.03
- NEW FIRE EXTINGUISHER RE: SPECIFICATIONS
- OPENING SCHEDULE RE: A11.01

**RCP LEGEND**

- MATERIALS**
- 2 x 2' GRID AND TILE SYSTEM - SEE SPECIFICATIONS
  - DEMO 2 x 2' GRID AND TILE SYSTEM - SEE SPECIFICATIONS
  - GYPSUM BOARD CEILING AS INDICATED ON PLAN. SEE FINISH PLAN FOR PAINT SPECIFICATIONS
  - CUSTOM CEILING AS INDICATED ON PLAN - SEE SPECIFICATIONS
- ANNOTATIONS**
- FINISHED CEILING HEIGHT AS INDICATED ON PLAN UON.
  - TYPE
  - HEIGHT A.F.F.
  - SUPPLY AIR GRILLE
  - RETURN AIR GRILLE
  - SPEAKER
  - CEILING MOUNTED CAMERA
  - WIRELESS ACCESS POINT
- LIGHT FIXTURES**
- 2 x 2' RECESSED DIRECT/INDIRECT LED
  - 2 x 4' RECESSED LENSED LED
  - RECESSED DIMMABLE DOWNLIGHT
  - RECESSED DIMMABLE DOWNLIGHT
  - UNDER CABINET
  - LED COVE LIGHT
  - WALL SCONCE
- LIFE SAFETY**
- EXIT SIGN, ARROW INDICATES PATH OF TRAVEL
  - SMOKE DETECTOR
  - LIFE SAFETY STROBE
  - SPRINKLER

**FIRE RATING LEGEND**

- 1-HOUR MIN FIRE-RESISTANCE RATED FIRE BARRIER 45 MIN OPENING PROTECTIVE
- 2-HOUR MIN FIRE-RESISTANCE RATED FIRE BARRIER 90 MIN OPENING PROTECTIVE
- SMOKE PARTITION
- 1-HOUR SMOKE BARRIER WALL 45 MIN OPENING PROTECTIVE
- 1-HOUR FIRE/SMOKE WALL 45 MIN OPENING PROTECTIVE
- 2-HOUR FIRE/SMOKE WALL 90 MIN OPENING PROTECTIVE

**TOILET ACCESSORY SCHEDULE**

ID	Item Description	Model #	Responsibility
B5	1 1/4" Nom Dia SST Grab Bar, Surface Mount, 36" Length	Bobrick - B-6806	CFCI
B6	1 1/4" Nom Dia SST Grab Bar, Surface Mount, 42" Length	Bobrick - B-6806	CFCI
C	Mirror Framed, 18"W x 36"H	Bobrick - B-290	CFCI
E	Toilet Tissue Dispenser, Surface Mount		CFCI
F3	Paper Towel Dispenser, Surface Mount		CFCI
H1	Toilet Seat Cover Dispenser		CFCI
I	Soap Dispenser, Surface Mount		CFCI
J1	Coat Hook	Bobrick - B-7671	CFCI

NOTE: FIELD VERIFY ALL EXISTING CONDITIONS & DIMENSIONS PRIOR TO BEGINNING OF WORK



CLIENT:  
**UTHealth**  
The University of Texas  
Health Science Center at Houston

CIVIL & STRUCTURAL  
ENGINEERING

Walter P Moore and Associates, Inc.  
1303 McKinney Street, Suite 1100  
Houston, TX 77002

MEP ENGINEERING

Johnston  
2001 Augusta Drive, Suite 1500  
Houston, TX 77057  
713.244.8300

PROJECT TITLE:  
**UTPB - VALET & DRIVEWAY RENOVATION**

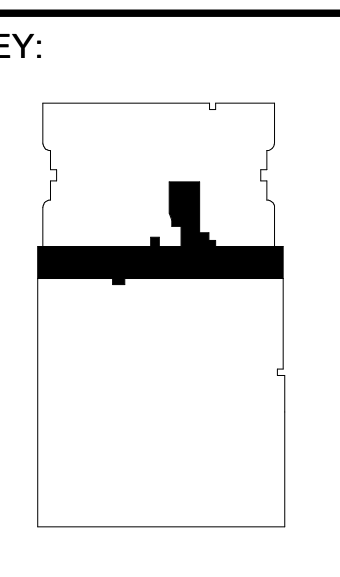

PROFESSIONAL SEAL:  
  
2019-12-16

PROJECT SUBMISSION:  
**ADDENDUM #01**

DATE: 2019-12-16

NO.	REVISION/ISSUE	YYYY MM DD
1	ADDENDUM #01	2019 12 16

PROJECT NO: 19-00032-00

DRAWN BY: JOHNSTON

SHEET TITLE:  
**ENLARGED FLOOR PLAN & REFLECTED CEILING PLAN - INTERIOR**

SHEET:  
**A3.01**

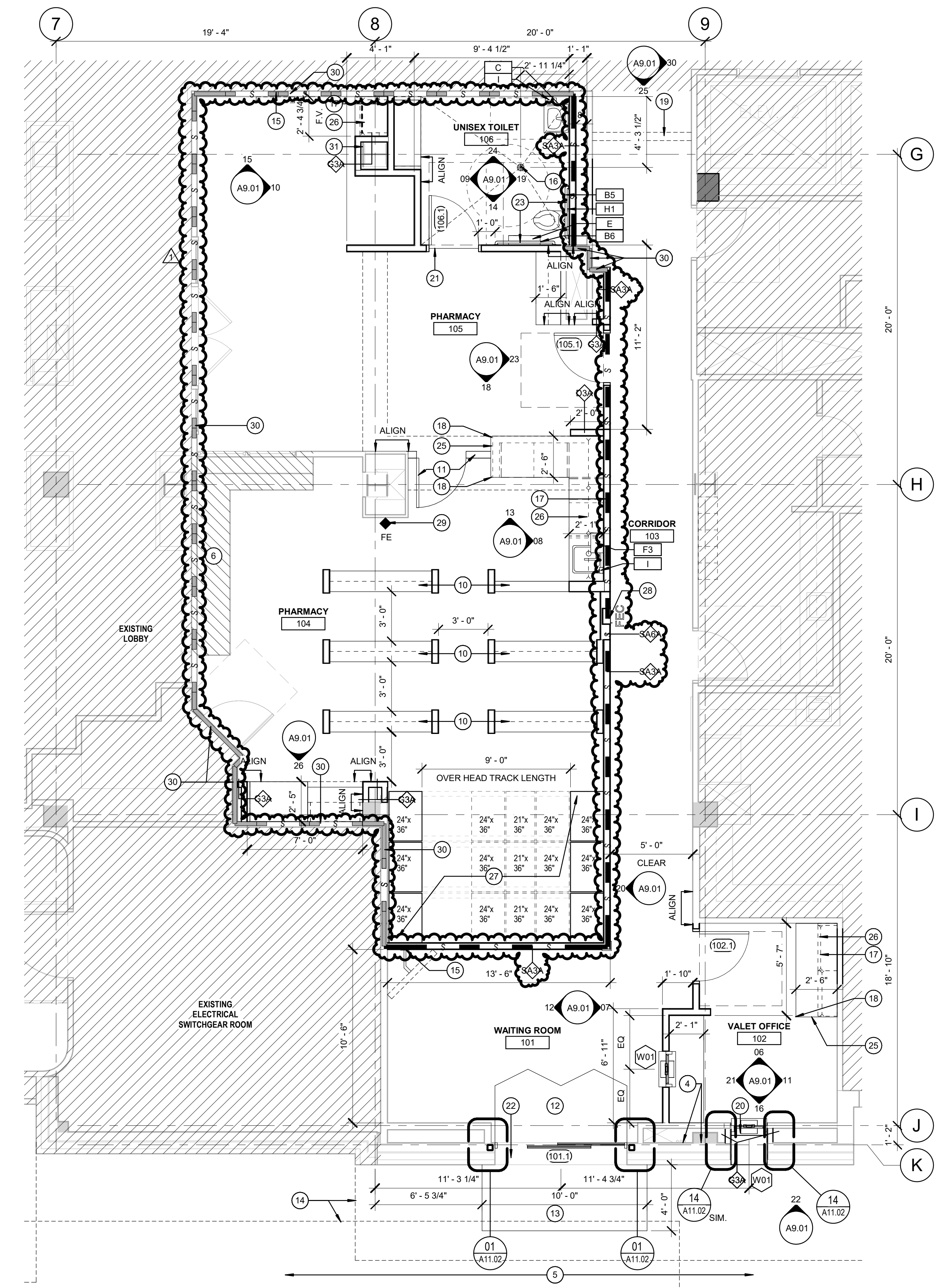
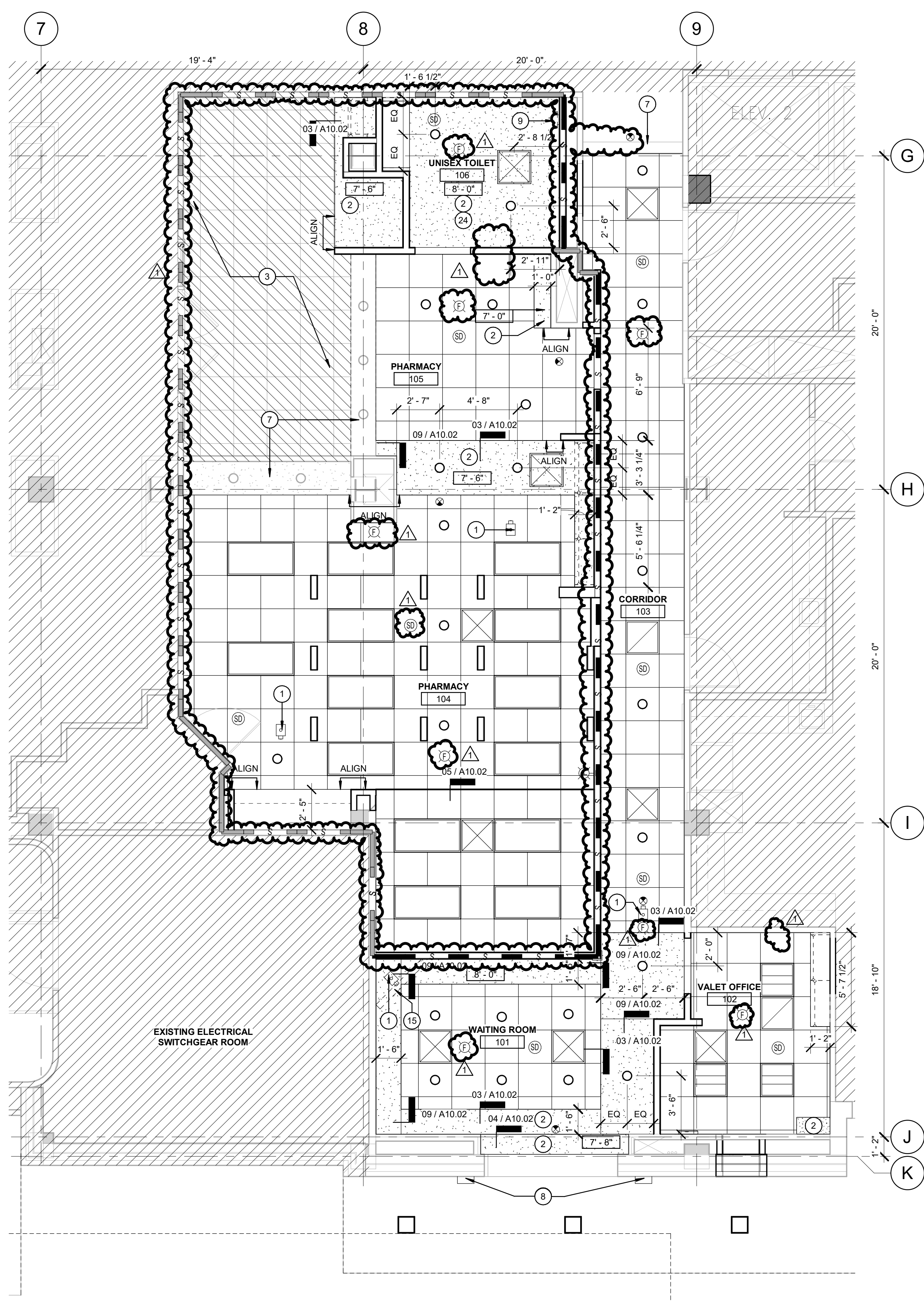

**26** ENLARGED REFLECTED CEILING PLAN - PHARMACY & VALET SUITE  
1/4" = 1'-0"

**16** ENLARGED FLOOR PLAN - PHARMACY & VALET SUITE  
1/4" = 1'-0"



**PARTITION TYPE GENERAL NOTES**

THE "PARTITION TYPE TAG" ILLUSTRATED BELOW, INDICATES THE ASSEMBLY OF THE COMPLETE EXTENT OF EACH PARTITION INDICATED BY THE TAG ON THE FLOOR PLANS, AND OTHER DRAWINGS IN THE PROJECT DOCUMENTS. REFER TO PARTITION TYPE DETAILS INDICATED BY THE "PARTITION TYPE" CHARACTER ON THE TAG. FOR EXAMPLE, PARTITION TAG ID "A" - REFERENCE TO DETAIL "TYPE A". REFER TO THE "FIRE RATING LEGEND" BELOW FOR THE FIRE-RESISTANCE CLASSIFICATION NOTED BY THE "FIRE RATING IDENTIFICATION" ON THE TAG. FOR EXAMPLE: "1" = 60 MIN FIRE-RESISTANCE RATED PARTITION ASSEMBLY; THE "METAL STUD/CMU NON WIDTH" CHARACTER ON THE TAG, AND AS SHOWN ON PARTITION TYPE DETAILS, INDICATES THE METAL STUD OR CMU NON WIDTH. OR EXAMPLE: "3" = 3-5/8" METAL STUDS.

THE "PARTITION TYPE MODIFIER" CHARACTERS REFER TO THE "PARTITION TYPE MODIFIER" NOTES SHOWN BELOW, WHICH APPLY TO THE COMPLETE EXTENT OF EACH PARTITION WHERE SO TAGGED.

THE "PARTITION KEYNOTE" CHARACTERS REFER TO NOTES SHOWN ON DRAWING KEYNOTE LEGENDS, WHICH APPLY TO THE COMPLETE EXTENT OF EACH PARTITION SO TAGGED. FOR EXAMPLE: "S50" = PARTITION SHALL COMPLY WITH SOUND TRANSMISSION CLASS LEVEL, STC-50.

PARTITION TYPE TAG:

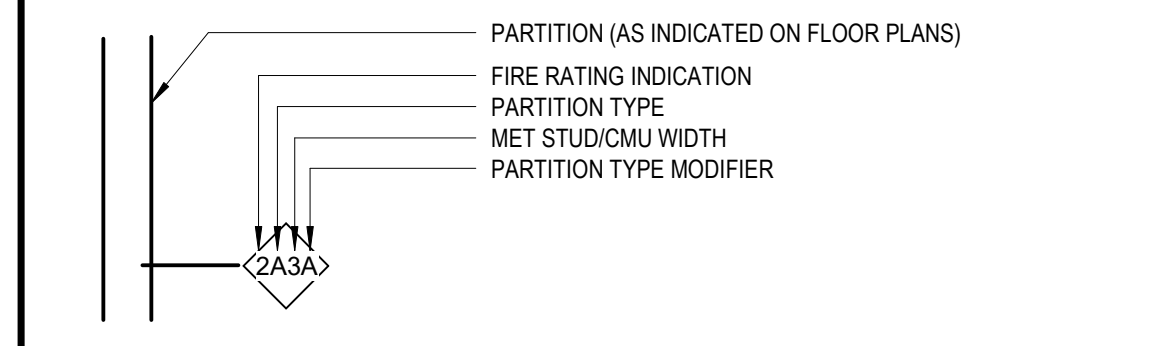

**PARTITION TYPE MODIFIERS:**

THE FOLLOWING NOTES APPLY TO THE FULL EXTENT OF EACH PARTN, WHERE "PARTN TYPE MODIFIER" CHARACTER(S) ARE SHOWN ON THE TAG:

A. PROVIDE ACOUSTIC BATT INSUL FULL DEPTH OF EACH METAL STUD CAVITY, AND ACOUSTIC BATT INSUL ABOVE TOP OF PARTN, MIN 2" EACH DIRECTION PERPENDICULAR TO PARTN

B. PROVIDE ACOUSTIC BATT INSUL FULL DEPTH OF EACH MET STUD CAVITY, AND ACOUSTIC BATT INSUL ABOVE TOP OF PARTN, MIN 2" EACH DIRECTION PERPENDICULAR TO PARTN

C. PROVIDE (1) ADDITIONAL LAYER OF 5/8" GYP BD ATTACHED TO (1) SIDE OF SCHED PARTN TYPE AS INDICATED. EXTEND FULL HT OF PARTN. PROVIDE ACOUSTIC BATT INSUL FULL WIDTH OF EACH STUD CAVITY

D. PROVIDE (1) ADDITIONAL LAYER OF 5/8" GYP BD ATTACHED TO BOTH SIDES OF SCHED PARTN TYPE. EXTEND FULL HT OF PARTN. PROVIDE ACOUSTIC BATT INSUL FULL WIDTH OF EACH STUD CAVITY

H. PROVIDE (1) LAYER OF 5/8" LAM ACOUSTIC GYP BD (TYPE X ON FIRE-RATED PARTN) ATTACHED TO FACE OF MET STUDS ON BOTH SIDES OF SCHED PARTN TYPE IN PLACE OF (1) LAYER OF SCHED GYP BD ON BOTH SIDES. AND PROVIDE ACOUSTIC BATT INSUL FULL DEPTH OF EACH MET STUD CAVITY

J. TERMINATE ADDITIONAL LAYERS OF GYP BD AS SCHED @ 4" ABOVE FINISH CLG, UON

L. PROVIDE PARTN TYPE AS SCHED, WITH MIN 20 GA MET STUDS @ 16" OC

M. PROVIDE PARTN TYPE AS SCHED, WITH MIN 18 GA MET STUDS @ 16" OC

N. PROVIDE PARTN TYPE AS SCHED, WITH MIN 16 GA MET STUDS @ 16" OC

P. PROVIDE (1) LAYER 5/8" WR GYP BD IN PLACE OF THE OUTSIDE LAYER OF GYP BD ON SCHED PARTN TYPE. MOUNT ON EACH FACE OF THE PARTN EXPOSED TO MOISTURE - EXTEND FULL HT OF PARTN UON

R. TERMINATE BOTTOM RUNNER TRACK OF THE PARTITION TYPE AT THE TOP OF RAISED FLOOR ACCESS PANEL ASSEMBLY. REFER TO ACCESS FLOOR SYSTEM DETAIL

T. PROVIDE THERMAL INSUL BATT FULL HT EACH STUD CAVITY, AS SPECIFIED

U. PROVIDE THERMAL INSULATION BATT FULL HEIGHT IN EACH STUD CAVITY, AS SPECIFIED.

**FIRE RATING LEGEND**

THE COMPLETE ASSEMBLY OF EACH PARTITION WITH A FIRE RATING INDICATION SYMBOL SHOWN ON THE TAG, SHALL COMPLY WITH ALL REQUIREMENTS OF THE FIRE-RESISTANCE RATING CLASSIFICATION:

SYMBOL	RATING CLASSIFICATION
<OMITTED>	NON-RATED PARTITION, UON
1	60 MIN FIRE-RESISTANCE RATED FIRE PARTITION
1S	60 MIN FIRE-RESISTANCE RATED & SMOKE BARRIER PARTITION
2	120 MIN FIRE-RESISTANCE RATED FIRE BARRIER
3	180 MIN FIRE-RESISTANCE RATED FIRE BARRIER
4	240 MIN FIRE-RESISTANCE RATED FIRE BARRIER

**PARTITION KEYNOTES**

THE FOLLOWING NOTES APPLY TO THE FULL EXTENT OF EACH PARTN, WHERE "PARTN KEYNOTE" CHARACTER(S) ARE SHOWN ON THE TAG. S - KEYNOTE "S" INDICATES THE COMPLETE PARTN ASSEMBLY SHALL COMPLY WITH THE SOUND TRANSMISSION CLASS LEVEL AS INDICATED - FOR EXAMPLE, S50 = STC 50.

**GENERAL NOTES -PARTITION**

- A. FIRE RESISTANT GYPSUM BOARD.
  - PARTITION FIRE AND/OR SMOKE RATINGS ARE INDICATED ON THE FLOOR PLANS BY DASHED LINE OR SYMBOL. SEE SHEETS G SERIES FOR LEGEND.
  - FIRE RATED PARTITION CONSTRUCTION MUST CONFORM TO GYPSUM ASSOCIATION (GA) DESIGNS, UNDERWRITERS LABORATORY (UL) TESTED DESIGNS OR OTHER TESTS APPROVED BY GOVERNING CODE AUTHORITIES. FIRE ASSEMBLY DESIGN NUMBERS (I.E., GA WP1200, UL U419) NOTED ON PARTITION DETAILS SHALL BE FOLLOWED WHEN A FIRE RATED ASSEMBLY IS INDICATED.
  - WHEN FIRE RATED PARTITIONS INTERSECT NON-RATED PARTITIONS, CARRY FIRE RATED ASSEMBLY THROUGH NON-RATED CONSTRUCTION.
  - CUTOUTS FOR ELECTRICAL DEVICES ON OPPOSITE SIDES OF PARTITIONS IN SAME STUD SPACE IS NOT ALLOWED.
  - PROVIDE UL SYSTEM PENETRATION AT PENETRATIONS AND TERMINATIONS IN ACCORDANCE WITH DIVISION 7.
  - PROVIDE FIRE STOPPING AND FIRE SAFING AT TOP OF PARTITION TERMINATIONS TO COMPLY WITH FIRE RATING ASSEMBLY AND EXTEND RATING TO STRUCTURAL DECK ABOVE.
- B. INSTALL BACKING PLATES AT ALL WALL-MOUNTED RAILINGS, WALL MOUNTED CASEWORK OR MILLWORK AND WALL MOUNTED DOOR BUMPERS.
- C. ALL CORRIDOR PARTITIONS TO BE CONSTRUCTED TO RESIST THE PASSAGE OF SMOKE OR TO MEET THE REQUIRED RATING.
- D. PROVIDE FOR DEFLECTION OF STRUCTURE AT TERMINATIONS OF PARTITION WITH STRUCTURE ABOVE IN ACCORDANCE TO DIVISIONS 4 AND 9.
- E. PROVIDE ACOUSTIC BATT INSULATION IN ALL PARTITIONS UNLESS NOTED OTHERWISE IN PARTITION TYPE.

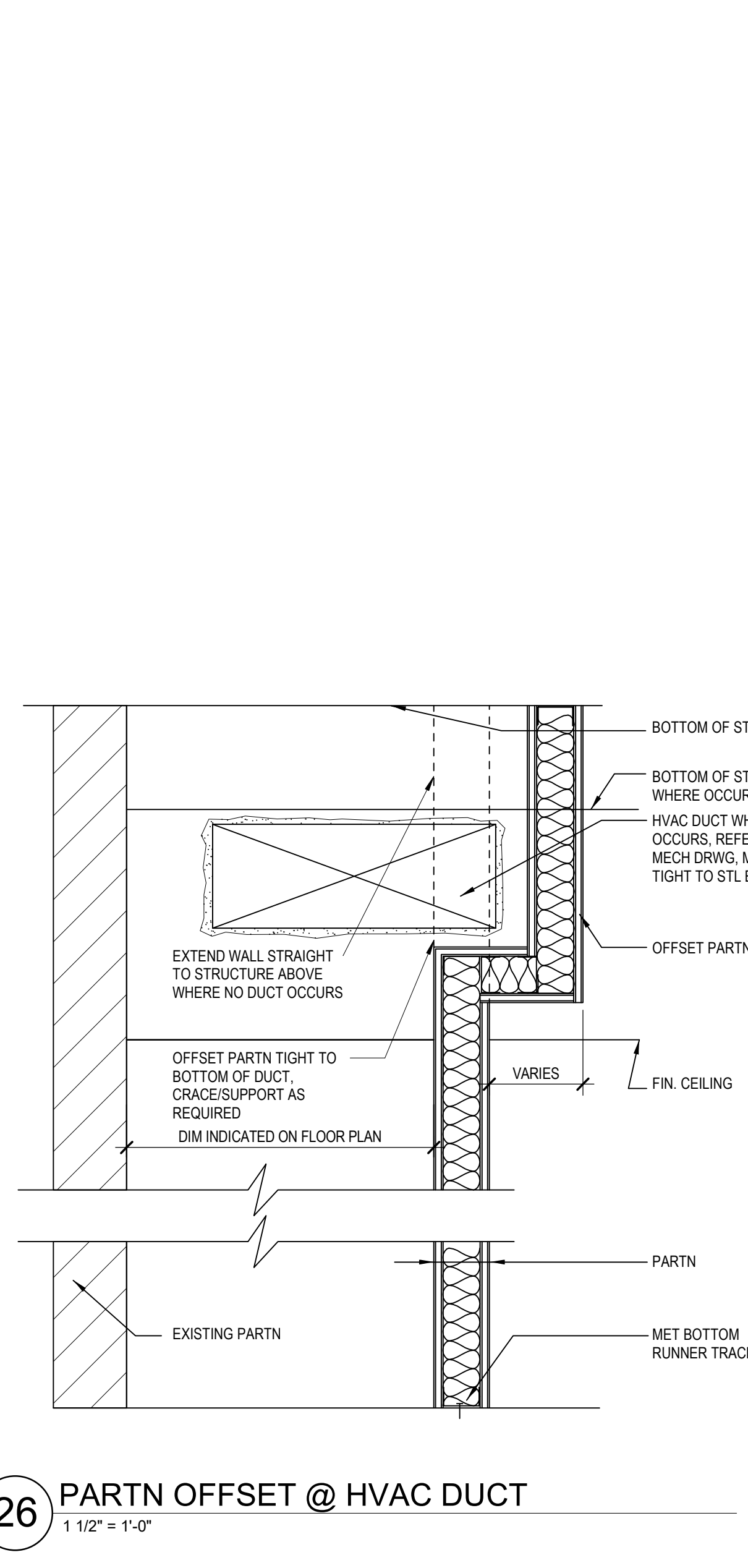
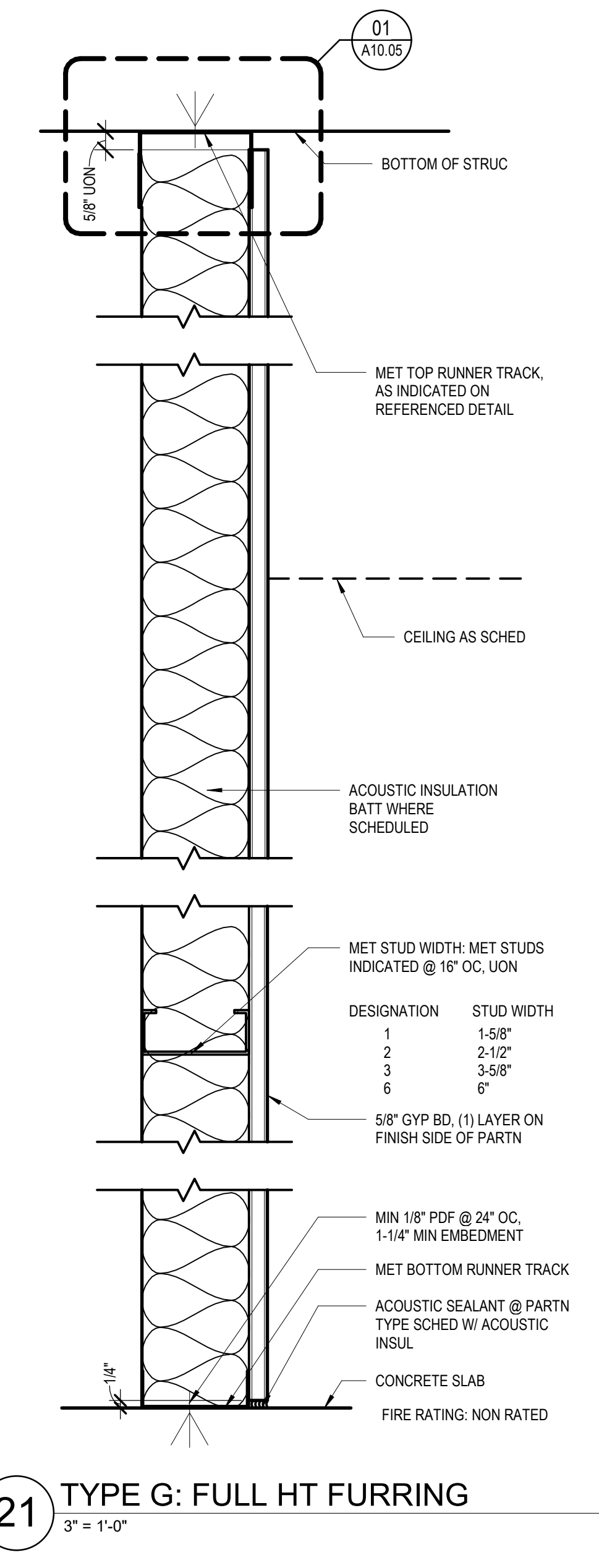
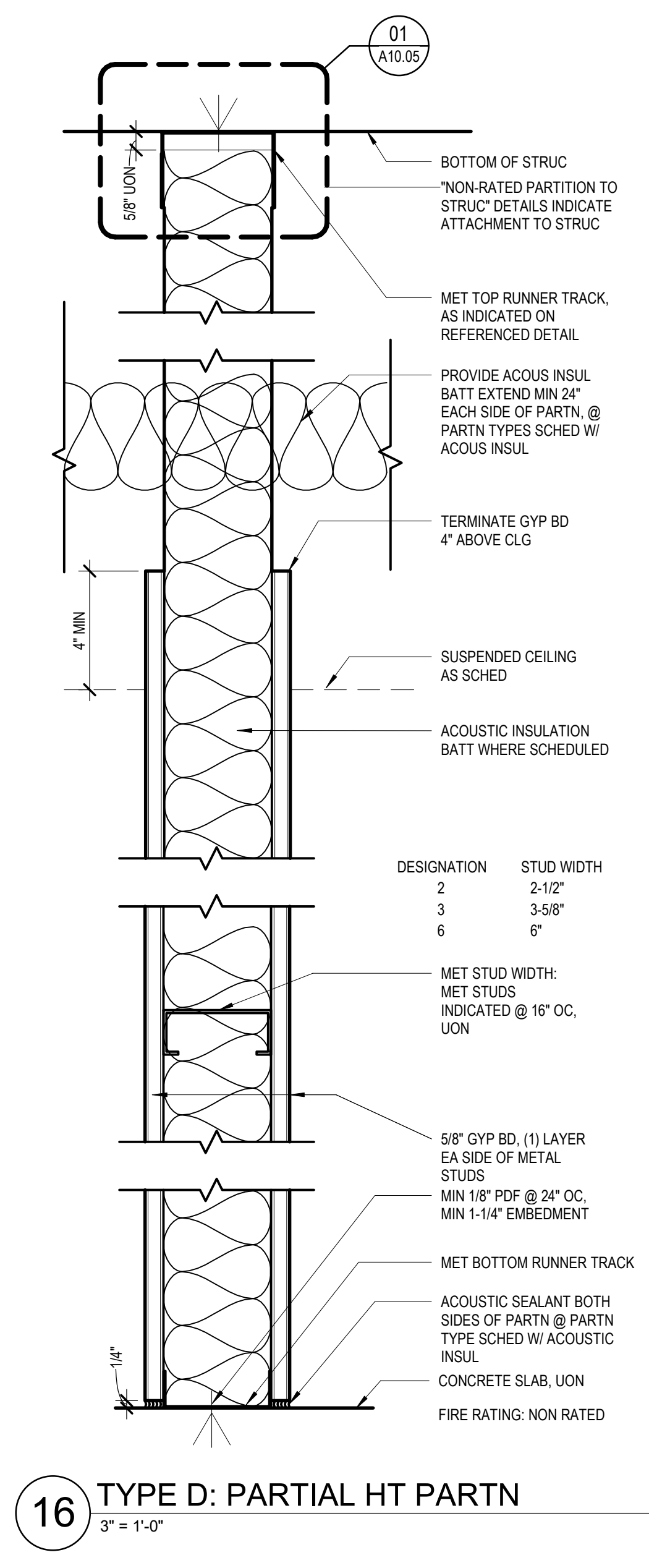
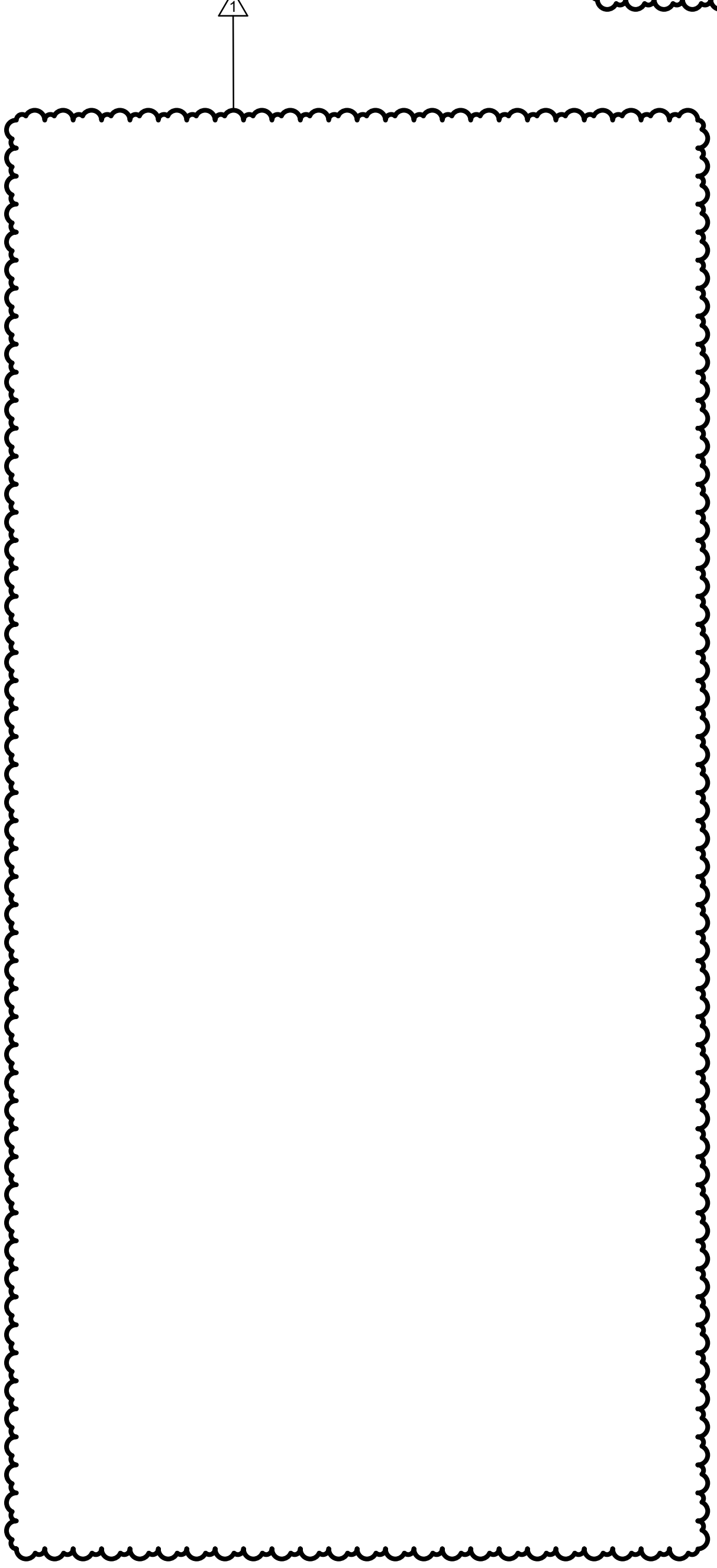
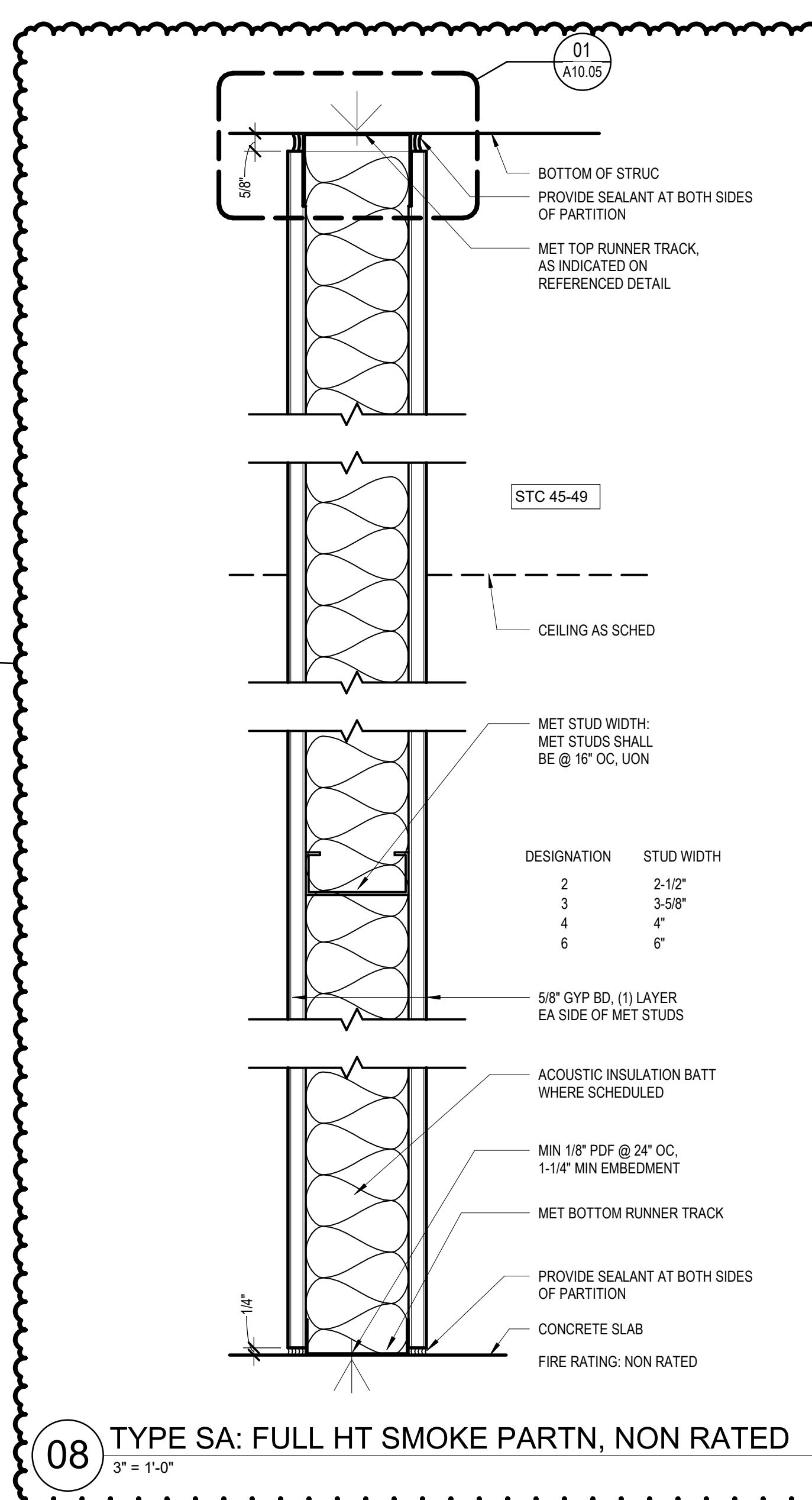

**26** PARTN OFFSET @ HVAC DUCT  
1 1/2" = 1'-0"

**21** TYPE G: FULL HT FURRING  
3" = 1'-0"

**16** TYPE D: PARTIAL HT PARTN  
3" = 1'-0"

**06** TYPE A: FULL HT PARTN, NON RATED  
3" = 1'-0"



DOOR SCHEDULE																
MARK	ROOM NAME	DOORS			FRAMES			DETAILS			FIRE RATING	HARDWARE GROUP	COMMENTS			
		TYPE	MATERIAL	FINISH	GLASS TYPE	WIDTH 1	WIDTH 2	HEIGHT	TYPE	MATERIAL				FINISH	GLASS TYPE	HEAD
101.1	WAITING ROOM	S1	GL	AL	GL-01	8'-0"	7'-8"	02	AL	AA	GL-01	02/A11.02	09/A11.02	01/A11.02	900	AUTOMATIC SLIDING DOOR
102.1	VALET OFFICE	F	WD	P-LAM	-	3'-0"	7'-0"	01	HM	PT	05/A11.02	04/A11.02	04/A11.02	K201		
105.1	PHARMACY	F	WD	P-LAM	-	3'-0"	7'-0"	01	HM	PT	05/A11.02	04/A11.02	04/A11.02	101		
106.1	UNISEX TOILET	F	WD	P-LAM	-	3'-0"	7'-0"	01	HM	PT	05/A11.02	04/A11.02	04/A11.02	341		

**HARDWARE GROUP NO. 101**  
FOR USE ON DOOR # 101.1  
PROVIDE EACH SGL DOOR WITH THE FOLLOWING:

QTY	DESCRIPTION	CATALOG NUMBER	FINISH	MFR
3	EA HINGE	5881 4.5 X 4.5 (3 EA. @ DOORS UNDER 90")	652	IVE
1	EA OFFICE ENTRY LOCK	70-8255-0B	626	SAR
1	EA PERMANENT CORE	MATCH EXISTING KEY SYSTEM	BES	BES
1	EA SURFACE CLOSER	4040VP RW/PA TBSRT (MTG PLT, SPGR AS REQ)	689	LCN
1	EA WALL STOP	WS406407CCV	630	IVE
1	EA GASKETING	188FSBK PSA (SR84 SILENCERS @ NON-RATED DOORS)	BK	ZER

**HARDWARE GROUP NO. 341**  
FOR USE ON DOOR # 106.1  
PROVIDE EACH SGL DOOR WITH THE FOLLOWING:

QTY	DESCRIPTION	CATALOG NUMBER	FINISH	MFR
3	EA HINGE	5881 4.5 X 4.5 (3 EA. @ DOORS UNDER 90")	652	IVE
1	EA PRIVACY WINDICATOR	490CCVAC @ OUTSIDE/6285 X 8 LEVER	626	SAR
1	EA SURFACE CLOSER	4040VP RW/PA TBSRT (MTG PLT, SPGR AS REQ)	689	LCN
1	EA WALL STOP	WS406407CCV	630	IVE
1	EA GASKETING	188FSBK PSA (SR84 SILENCERS @ NON-RATED DOORS)	BK	ZER

**HARDWARE GROUP NO. 900**  
FOR USE ON DOOR # 101.1  
PROVIDE EACH SGL DOOR WITH THE FOLLOWING:

QTY	DESCRIPTION	CATALOG NUMBER	FINISH	MFR
3	EA HINGE	5881 4.5 X 4.5 (3 EA. @ DOORS UNDER 90")	652	IVE
1	EA TRILOCKY KEYPAD LOCK	DL2L303C	TR1	US26D
1	EA PERMANENT CORE	MATCH EXISTING KEY SYSTEM	BES	BES
1	EA WALL STOP	WS406407CCV	630	IVE
1	EA GASKETING	188FSBK PSA (SR84 SILENCERS @ NON-RATED DOORS)	BK	ZER

**HARDWARE GROUP NO. K201**  
FOR USE ON DOOR # 102.1  
PROVIDE EACH SGL DOOR WITH THE FOLLOWING:

QTY	DESCRIPTION	CATALOG NUMBER	FINISH	MFR
3	EA HINGE	5881 4.5 X 4.5	BBLK	IVE
1	EA TRILOCKY KEYPAD LOCK	DL2L303C	TR1	US26D
1	EA PERMANENT CORE	MATCH EXISTING KEY SYSTEM	BES	BES
1	EA WALL STOP	WS406407CCV	630	IVE
1	EA GASKETING	188FSBK PSA (SR84 SILENCERS @ NON-RATED DOORS)	BK	ZER

WINDOW SCHEDULE					
MARK	ROOM NAME	ROUGH OPENING		GLAZING TYPE	SILL HEIGHT
		WIDTH	HEIGHT		
W01	VALET OFFICE	2'-1 3/4"	3'-6"	GL-02	2'-7 1/2"
W01	WAITING	2'-1 3/4"	3'-6"	GL-02	2'-7 1/2"

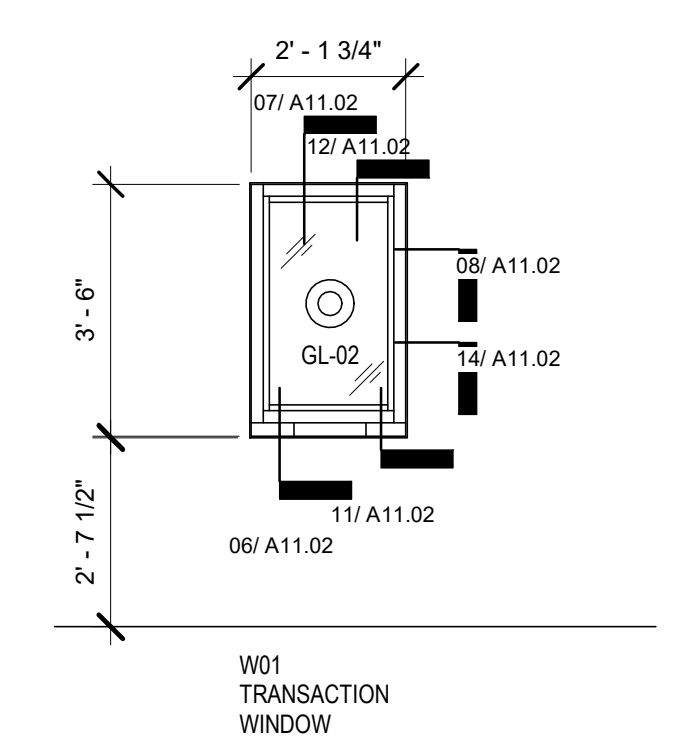

**28 WINDOW TYPE DIAGRAM**  
3/8" = 1'-0"

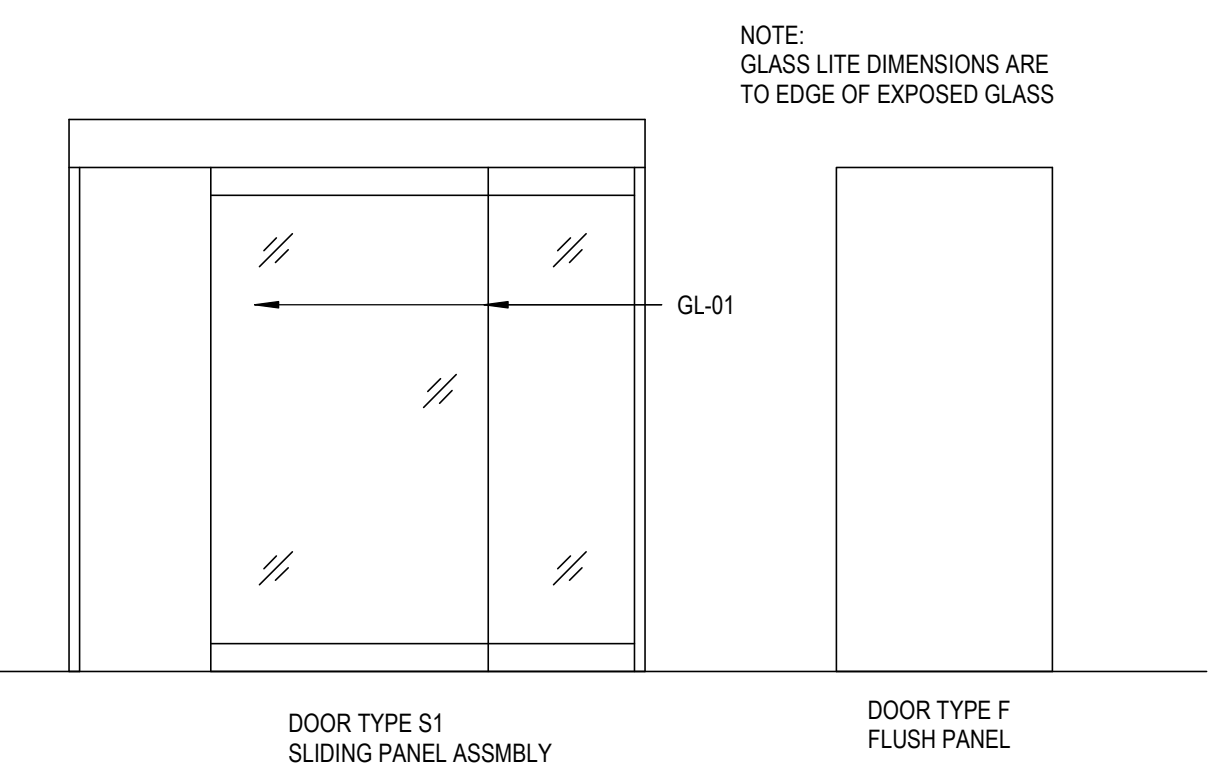

**27 DOOR TYPE DIAGRAM**  
3/8" = 1'-0"

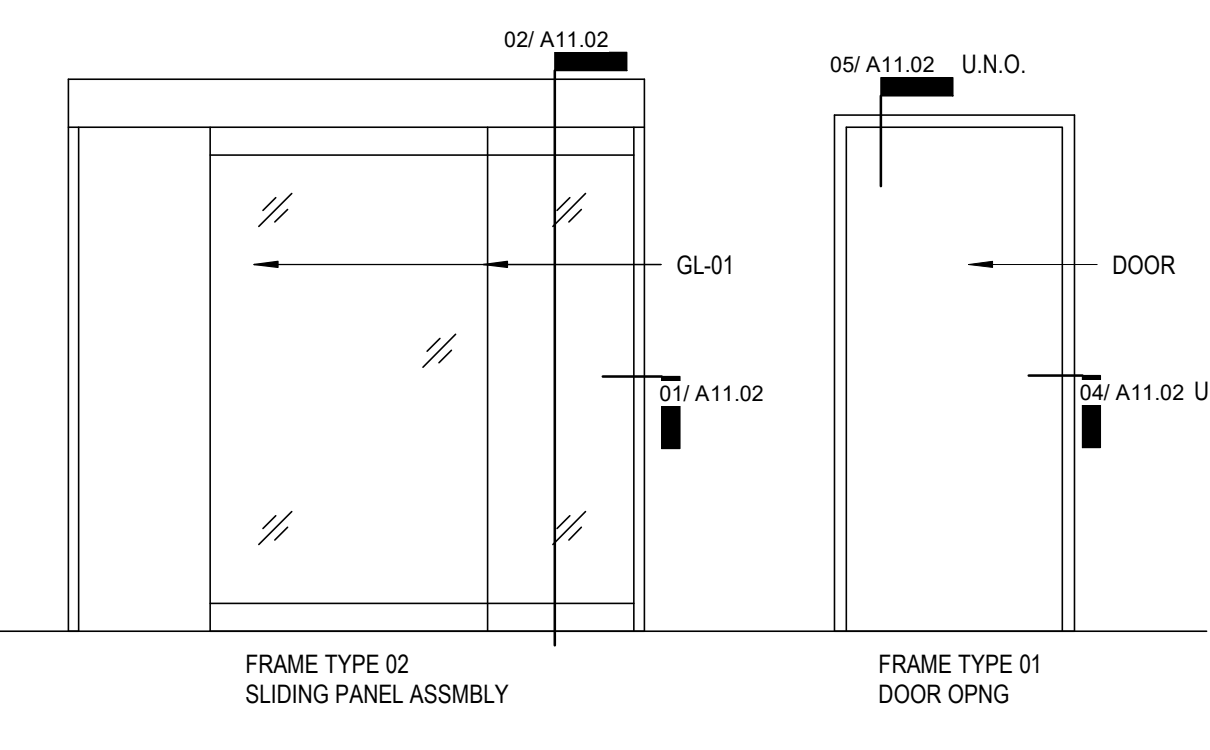

**26 DOOR TYPE DIAGRAM**  
3/8" = 1'-0"

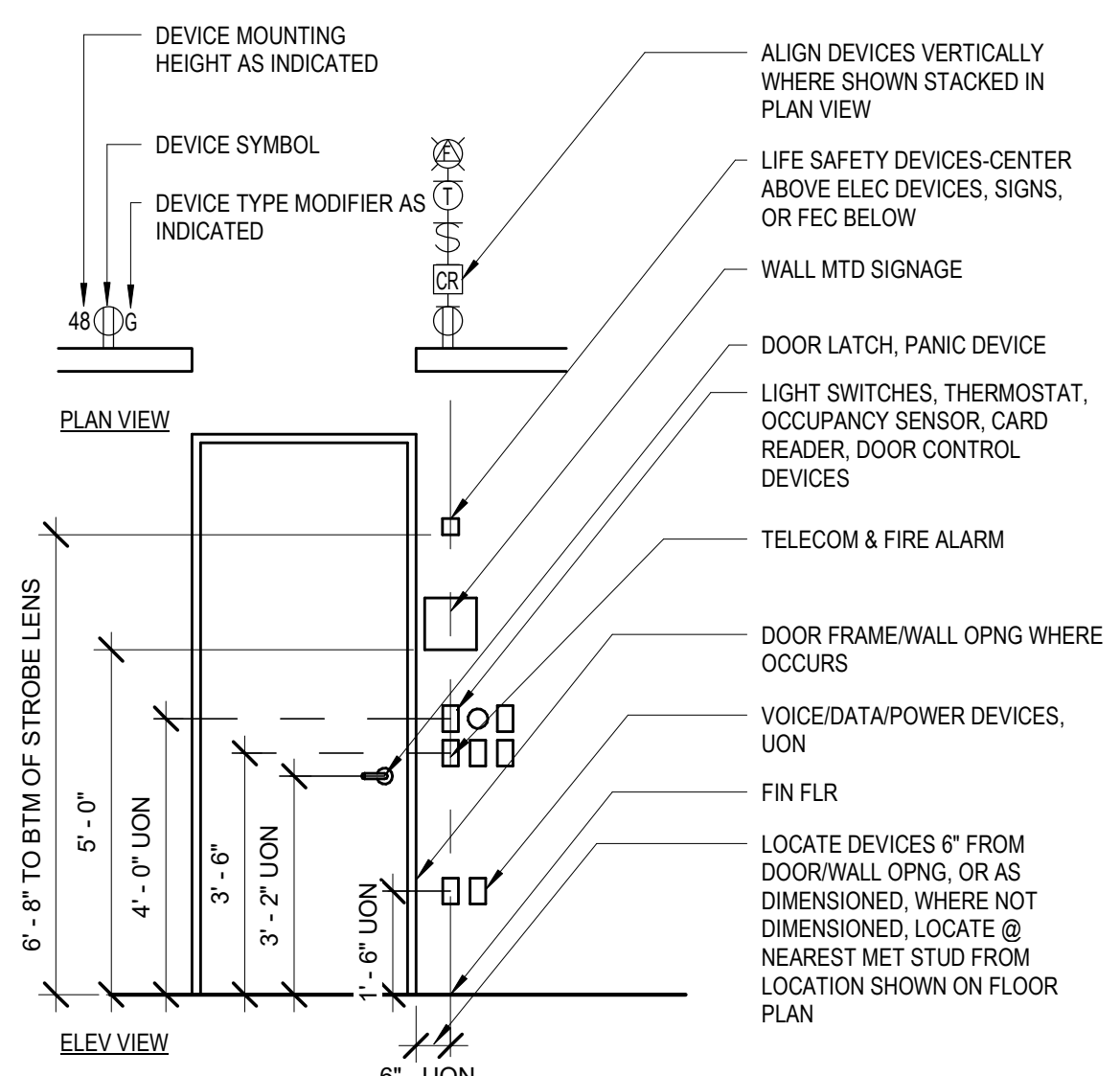
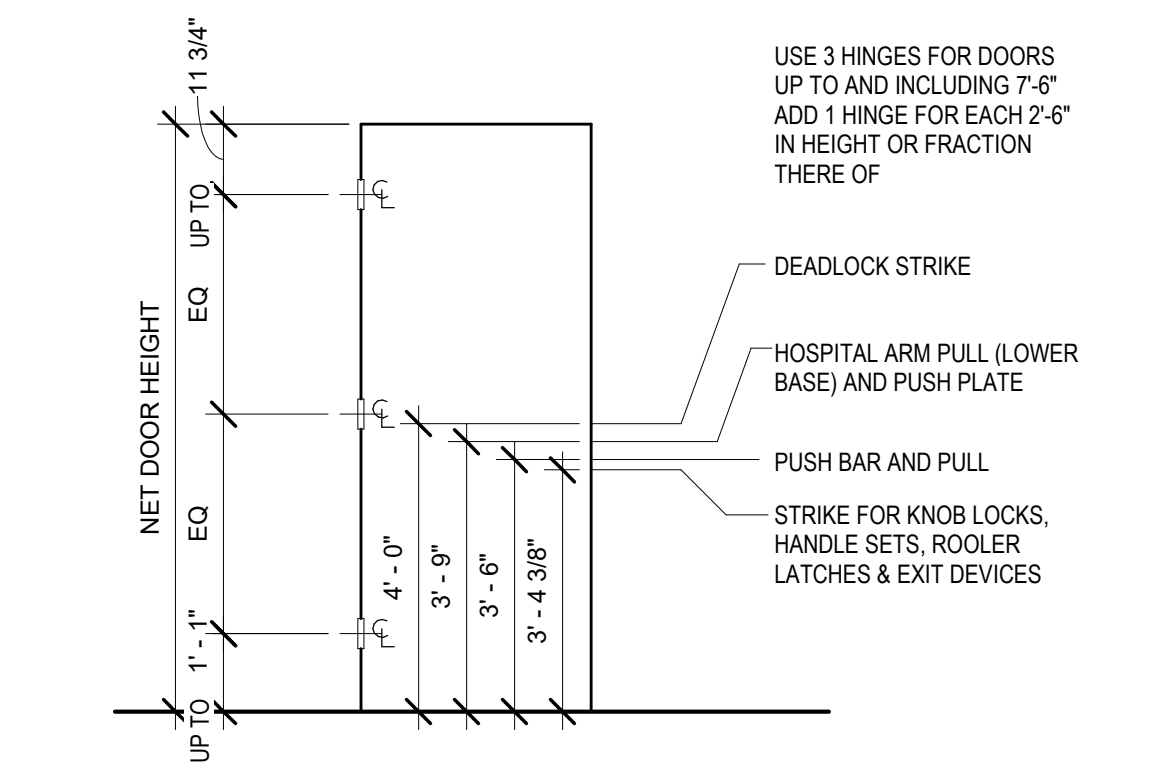

**06 GENERAL DEVICE ALIGNMENT DIAGRAM**  
3/8" = 1'-0"

**GENERAL NOTES - DOORS**

A DOOR AND FRAME ASSEMBLIES SHALL COMPLY WITH ALL SCHEDULED REQUIREMENTS, GENERAL NOTES & LEGENDS, DOOR AND FRAME DETAILS, AND PROJECT SPECIFICATIONS.

B "OPENING IDENTIFIERS" INDICATED ON THE SCHEDULE IDENTIFY DOOR-FRAME ASSEMBLY TYPES, WHICH ARE SHOWN THE DOOR TAG FOR EACH DOOR OPENING ON THE FLOOR PLANS.

C "DOOR PANEL TYPES" AND "FRAME TYPES" INDICATED ON THE SCHEDULE REFER TO THE "DOOR TYPE DIAGRAMS" AND "FRAME TYPE DIAGRAMS", AND "CONSTRUCTION TYPES", "FINISH TYPES", "GLASS TYPES" REFER TO CORRESPONDING LEGENDS SHOWN ON THE DOOR SCHEDULE SHEET.

D DOOR WIDTH AND DOOR HEIGHT INDICATE THE NOMINAL DIMENSIONS OF EACH DOOR LEAF (SHOWN IN INCHES). DOOR WIDTH FOR ASSEMBLIES WITH A SINGLE DOOR LEAF IS INDICATED BY "DOOR WIDTH 1," ACTUAL DOOR DIMENSIONS SHALL COMPLY WITH HEAD - JAMB - MULLION - SILL DETAILS AND DOOR SPACING AND CLEARANCES AS SPECIFIED. NOTE THAT ALL DOOR THICKNESSES ARE 1-3/4", UON.

E FRAME ASSEMBLIES SHALL COMPLY WITH "HEAD - JAMB - MULLION - SILL" DETAILS AS SCHEDULED. DETAIL NUMBERS REFERENCE SHEET A11.02, UON.

F "FIRE RATING" SYMBOL INDICATES THE FIRE RATING MINUTES FOR EACH ASSEMBLY, AS INDICATED BY THE "FIRE RATING LEGEND" ON THE DOOR SCHEDULE SHEET.

G "HARDWARE GROUP" NUMBER REFERS TO GROUPS SHOWN ON THE DOOR SCHEDULE SHEET, AND REQUIREMENTS INDICATED BY THE "INTERIOR HARDWARE TYPE" LIST, "HARDWARE TYPE NOTES", AND PROJECT SPECIFICATIONS. REFER TO SHEET: A11.02 FOR HARDWARE SCHEDULE

H "TYPE REMARKS" REFER TO REQUIREMENTS INDICATED BY THE "TYPE REMARK LEGEND" ON THE DOOR SCHEDULE SHEET

I DOOR UNDERCUT FOR RATED DOORS TO BE 3/4" MAX.

J DOOR UNDERCUT FOR NON-RATED DOORS TO BE 1" MAX.

K REFER TO SHEET: A11.02 FOR DOOR/WINDOW TYPES & DETAILS

L REFER TO SHEET: A11.01 FOR HARDWARE SETS

M THE HARDWARE SETS REPRESENT THE DESIGN INTENT AND DIRECTION OF THE OWNER AND ARCHITECT. THEY ARE A GUIDELINE ONLY AND SHOULD NOT BE CONSIDERED A DETAILED HARDWARE SCHEDULE. DISCREPANCIES, CONFLICTING HARDWARE AND MISSING ITEMS SHOULD BE BROUGHT TO THE ATTENTION OF THE ARCHITECT WITH CORRECTIONS MADE PRIOR TO THE BIDDING PROCESS. OMITTED ITEMS NOT INCLUDED IN A HARDWARE SET SHOULD BE SCHEDULED WITH THE APPROPRIATE ADDITIONAL HARDWARE REQUIRED FOR PROPER APPLICATION AND FUNCTIONALITY.

**DOOR TYPE LEGEND**

F FLUSH PANEL DOOR  
S1 SLIDING DOOR ASSEMBLY

**FRAME TYPE LEGEND**

01 STANDARD 3-PIECE DOOR FRAME  
02 SLIDING DOOR ASSEMBLY  
NOTE A SUFFIX MODIFIER (AL, GL, HM, SS, WD) DENOTES FRAME MATERIAL

**FINISH TYPE LEGEND**

AA ANODIZED ALUMINUM  
PL PLASTIC LAMINATE  
SSM SOLID SURFACE MATERIAL

**CONSTRUCTION TYPE LEGEND**

AL ALUMINUM  
GL GLASS - GLASS TYPE AS SCHEDULED

**GLASS TYPE LEGEND**

GL-01 1/4" TEMPERED GLASS, CLEAR  
GL-02 3/4" IMPACT RESISTANT SECURITY GLASS, CLEAR  
GL-03 1/4" TEMPERED SPANDREL GLASS

**CLIENT:**

**UTHealth**  
The University of Texas  
Health Science Center at Houston

**CIVIL & STRUCTURAL ENGINEERING**

Walter P Moore and Associates, Inc.  
1301 McKinney Street, Suite 1100  
Houston, TX 77002  
713.244.8300  
www.walterpmoore.com

**MEP ENGINEERING**

Johnston  
2803 Augusta Drive, Suite 1500  
Houston, TX 77057  
713.244.8300  
www.johnstonllc.com  
TYPE FIRM REGISTRATION # F-421

**PROJECT TITLE:**  
UTPB - VALET & DRIVEWAY RENOVATION

**PLAN KEY:**

**PROFESSIONAL SEAL:**

2019-12-16

**PROJECT SUBMISSION:**

**DATE:** 2019-12-16

NO.	REVISION/ISSUE	YYYY MM DD
1	ADDENDUM #01	2019 12 16

**PROJECT NO.:** 19-00032-00  
**DRAWN BY:** JOHNSTON

**SHEET TITLE:**  
OPENING SCHEDULE

**SHEET:**  
A11.01

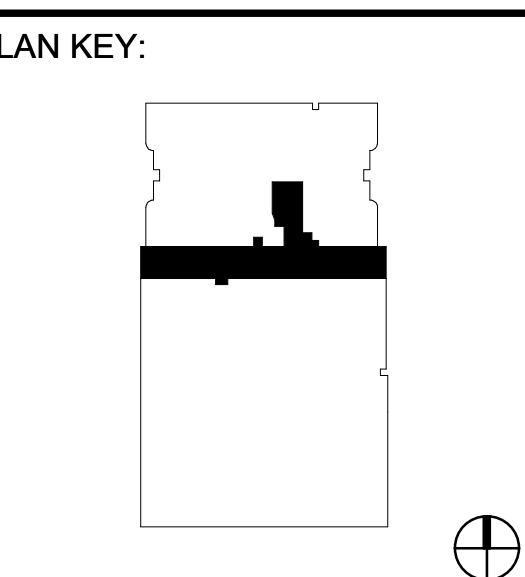
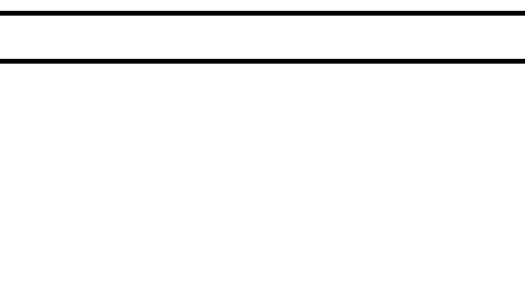

NO.	REVISION/ISSUE	YYYY MM DD
1	ADDENDUM #01	2019 12 16

**PROJECT NO.:** 19-00032-00  
**DRAWN BY:** JOHNSTON

**SHEET TITLE:**  
OPENING SCHEDULE

**SHEET:**  
A11.01



AIR DEVICE SCHEDULE								
Key name	TYPE	TYPE DESCRIPTION	MANUFACTURER	MODEL	MODULE SIZE	MATERIAL	FINISH	DESCRIPTION
A-24x24 CEILING SUPPLY	A	SUPPLY DIFFUSER	TITUS	OMNI-AA	24 x 24	ALUMINUM	BAKED ENAMEL	SQUARE PANEL FACE LAY-IN HIGH CAPACITY CEILING DIFFUSER. 24x24 FACE UNLESS OTHERWISE SPECIFIED. NECK DIAMETER SPECIFIED IN SCHEDULE NOTES. PROVIDE AIR PATTERN CONTROLLER.
B-24x24 CEILING RETURN/EXHAUST	B	CEILING RETURN / EXHAUST GRILLE	TITUS	PAR-AA	24 x 24	ALUMINUM	BAKED ENAMEL	24x24 PERFORATED FACE GRILLE. PLENUM RETURN GRILLE WITH 22x22 NECK UNLESS NOTED OTHERWISE IN PLANS. DUCTED EXHAUST GRILLE WITH NECK DIAMETER SPECIFIED IN SCHEDULE NOTES AND RUN-OUT DUCT SIZE AS SPECIFIED ON PLANS.
X - EXISTING	X	EXISTING AIR DEVICE	TITUS	EXISTING	PER PLANS	EXISTING	EXISTING	EXISTING AIR DEVICE.

KEY:

INLET DUCT SIZE SCHEDULE	
6"	0-100 CFM
8"	100-220 CFM
10"	225-330 CFM
12"	330-510 CFM
14"	510-700 CFM

AIR DEVICE SCHEDULE NOTES:

- PROVIDE SQUARE TO ROUND TRANSITION FOR TYPE A CEILING DIFFUSERS FOR DUCT SIZE AND CFM INDICATED (SEE INLET DUCT SIZE CHART, THIS SCHEDULE).
- PROVIDE FINISH AS SPECIFIED ON ARCHITECTURAL DRAWINGS.
- PROVIDE VOLUME DAMPER AT BRANCH DUCT TAP ABOVE ACCESSIBLE CEILING.

VAV BOX SCHEDULE - ELECTRIC HEAT						
UNIT	INLET SIZE	MAX. AIR FLOW	MIN. AIR FLOW	HEATING CFM	HEATING KW	VOLTS/PH/Hz
VAV-1-1	10"	830 CFM	275 CFM	830 CFM	11	480/3/60

- NOTES:
- PROVIDE TOP AND BOTTOM ACCESS PANEL FOR SERVICE.
  - PROVIDE SINGLE POINT ELECTRICAL CONNECTION WITH FAN DISCONNECT.
  - ELECTRIC HEATER SHALL BE 4 STAGES.

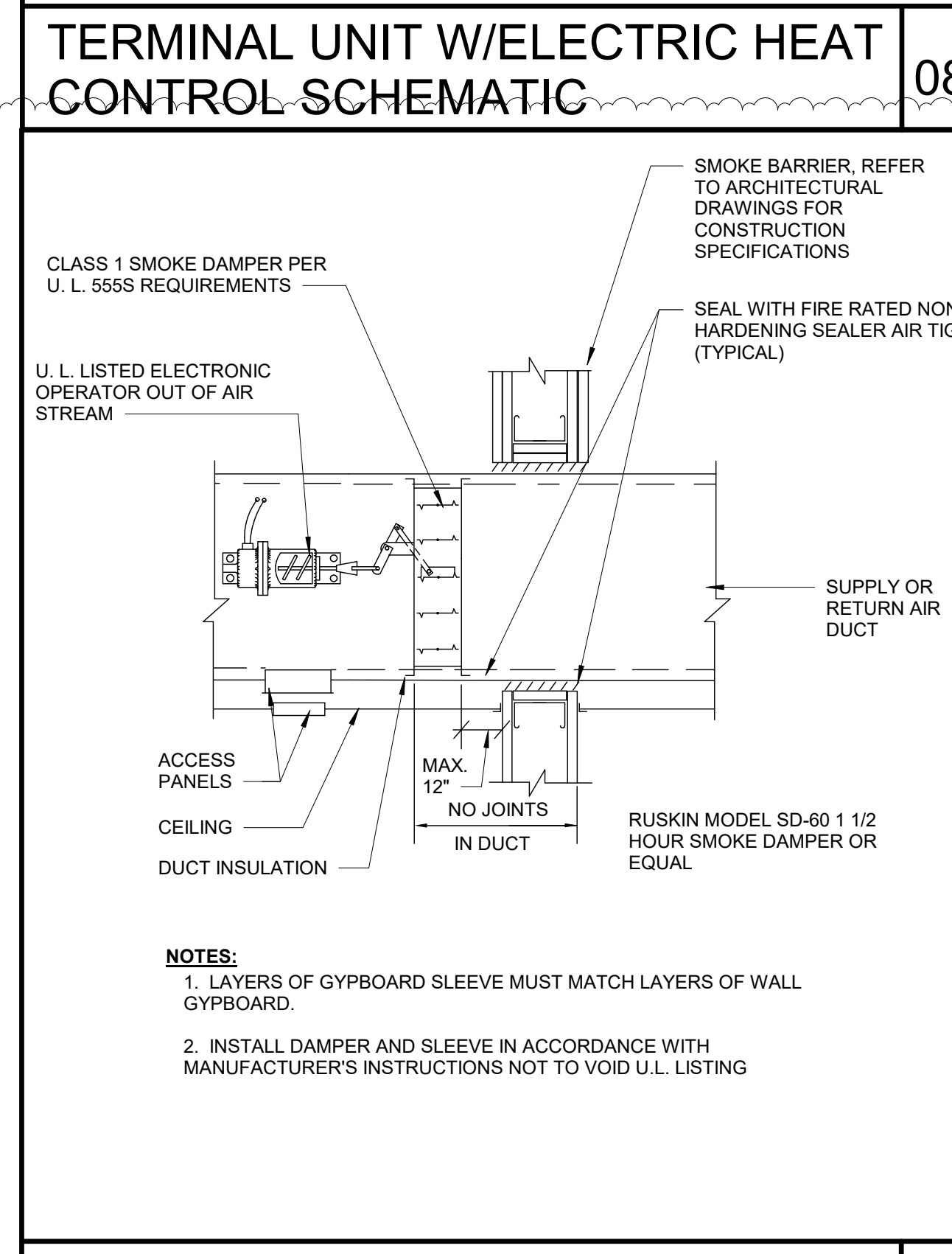
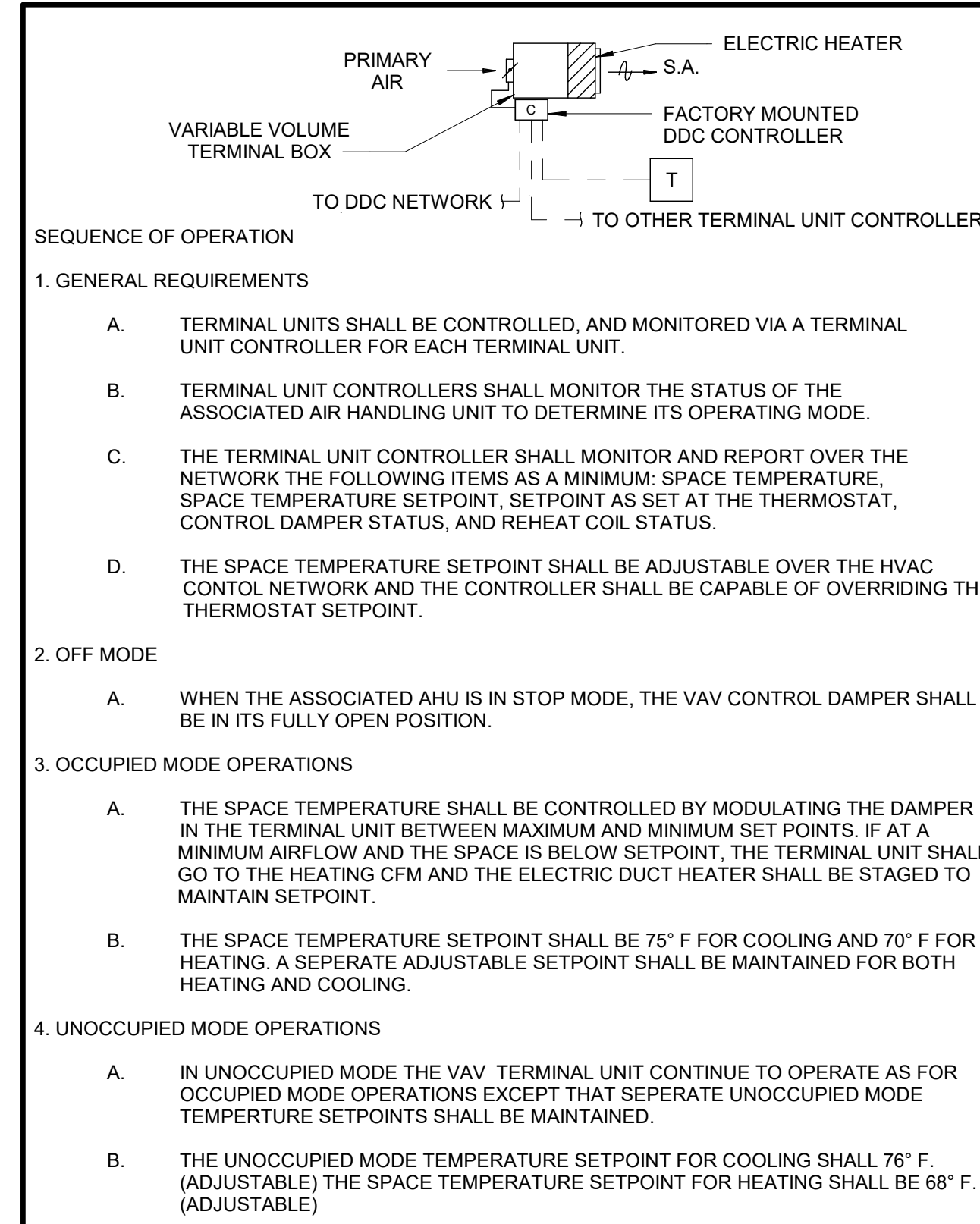

SMOKE DAMPER 07

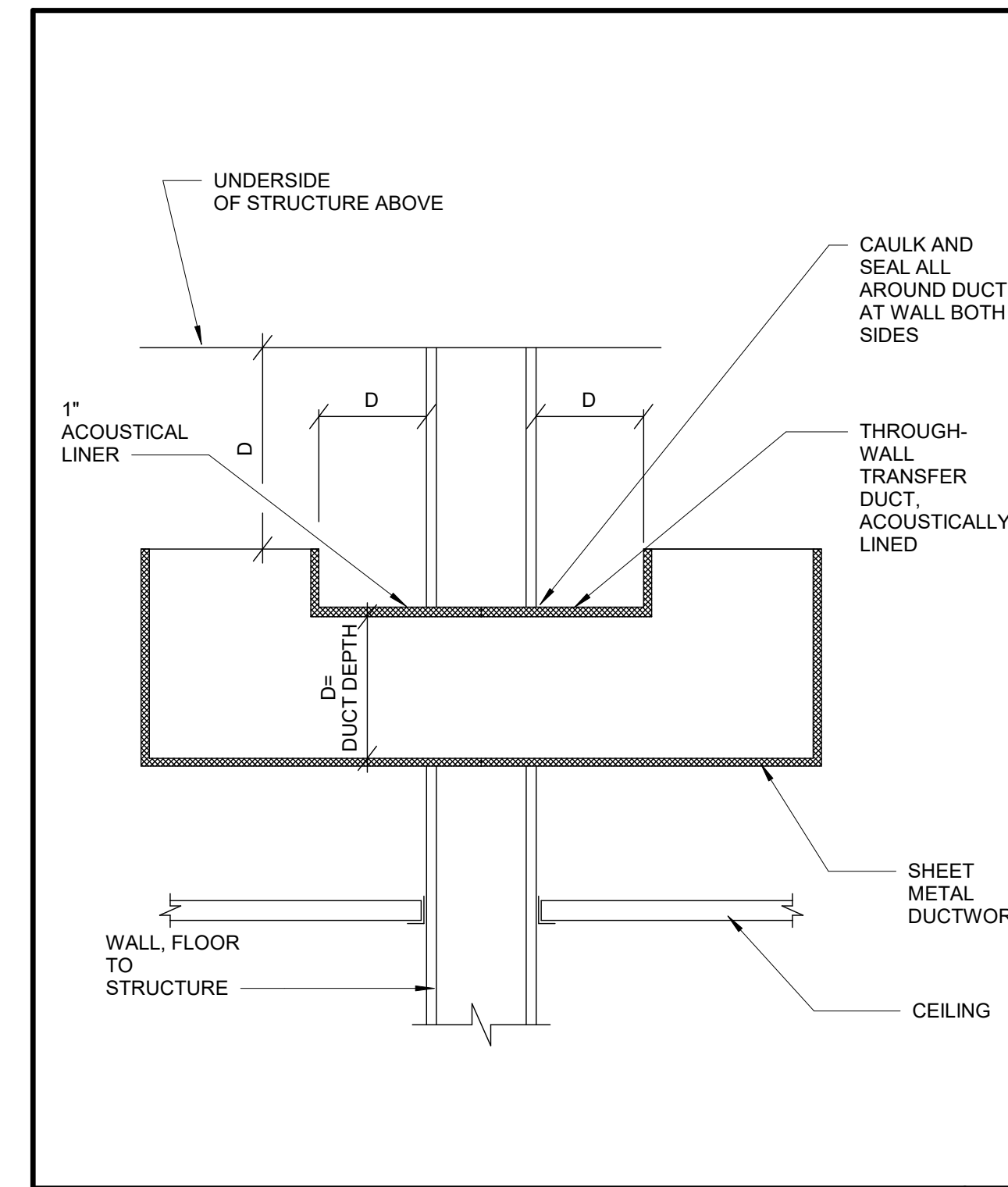

TRANSFER DUCT WITH GRILLES 06

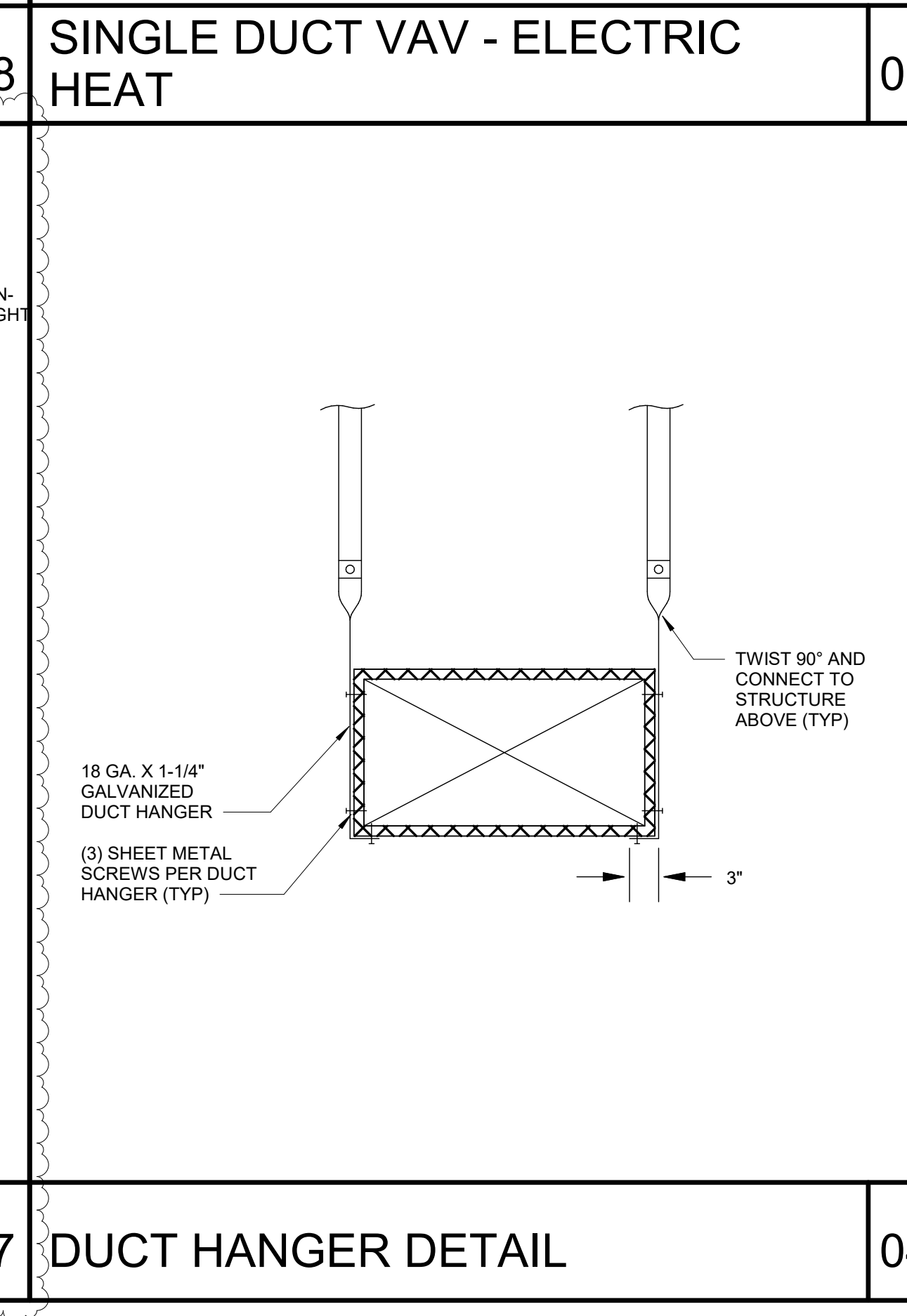
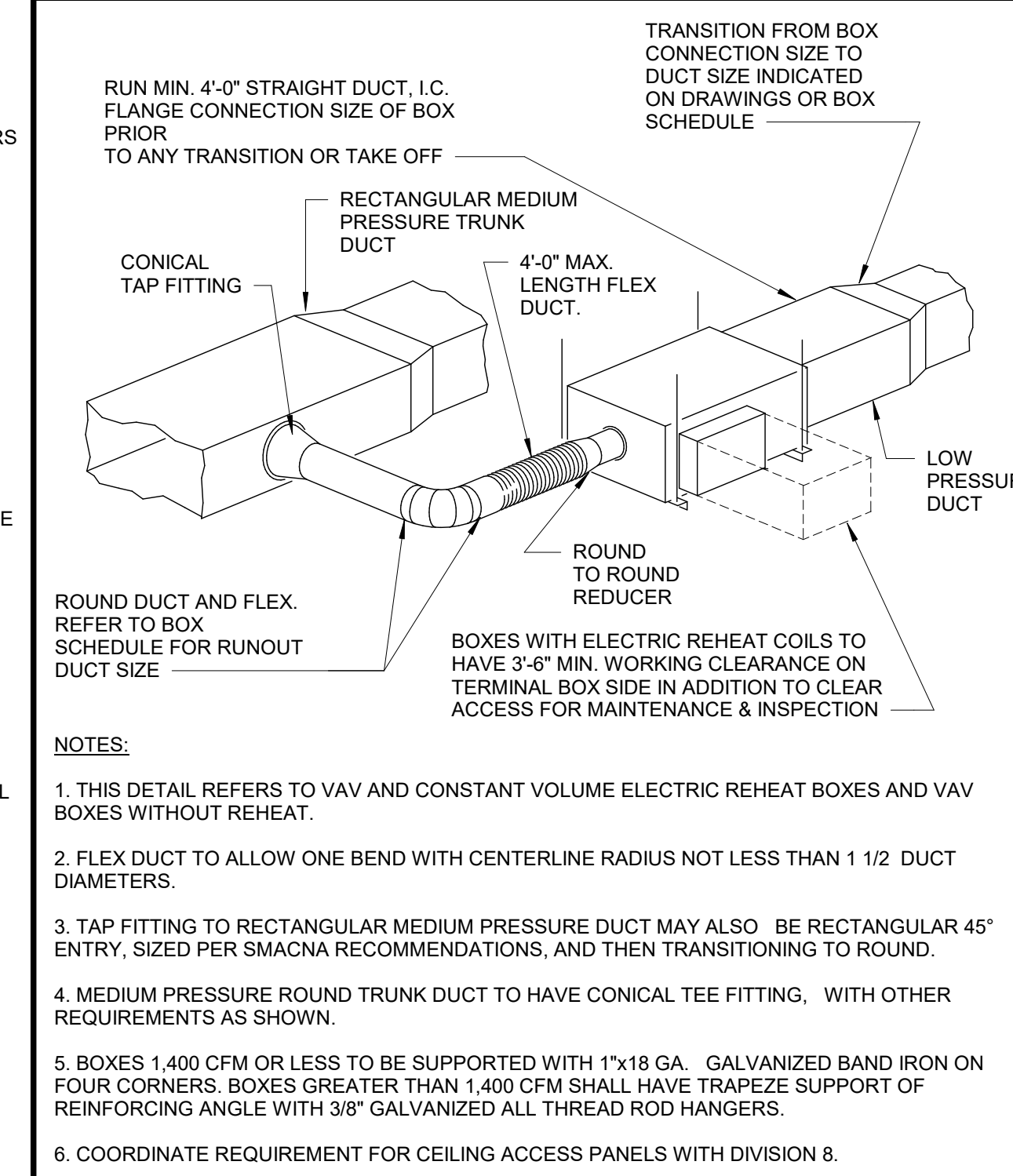

DUCT HANGER DETAIL 04

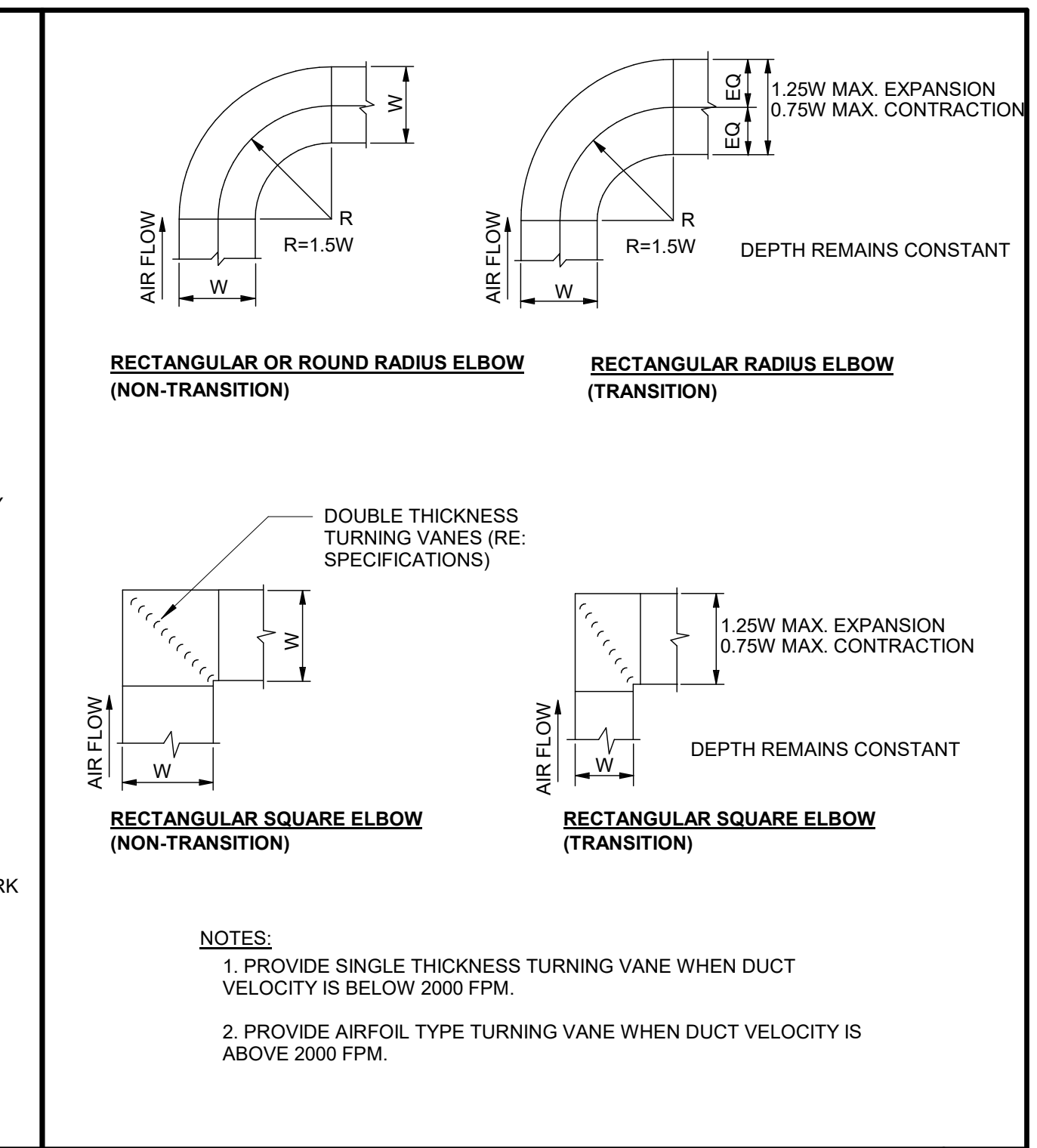

DUCT ELBOW DETAIL 03

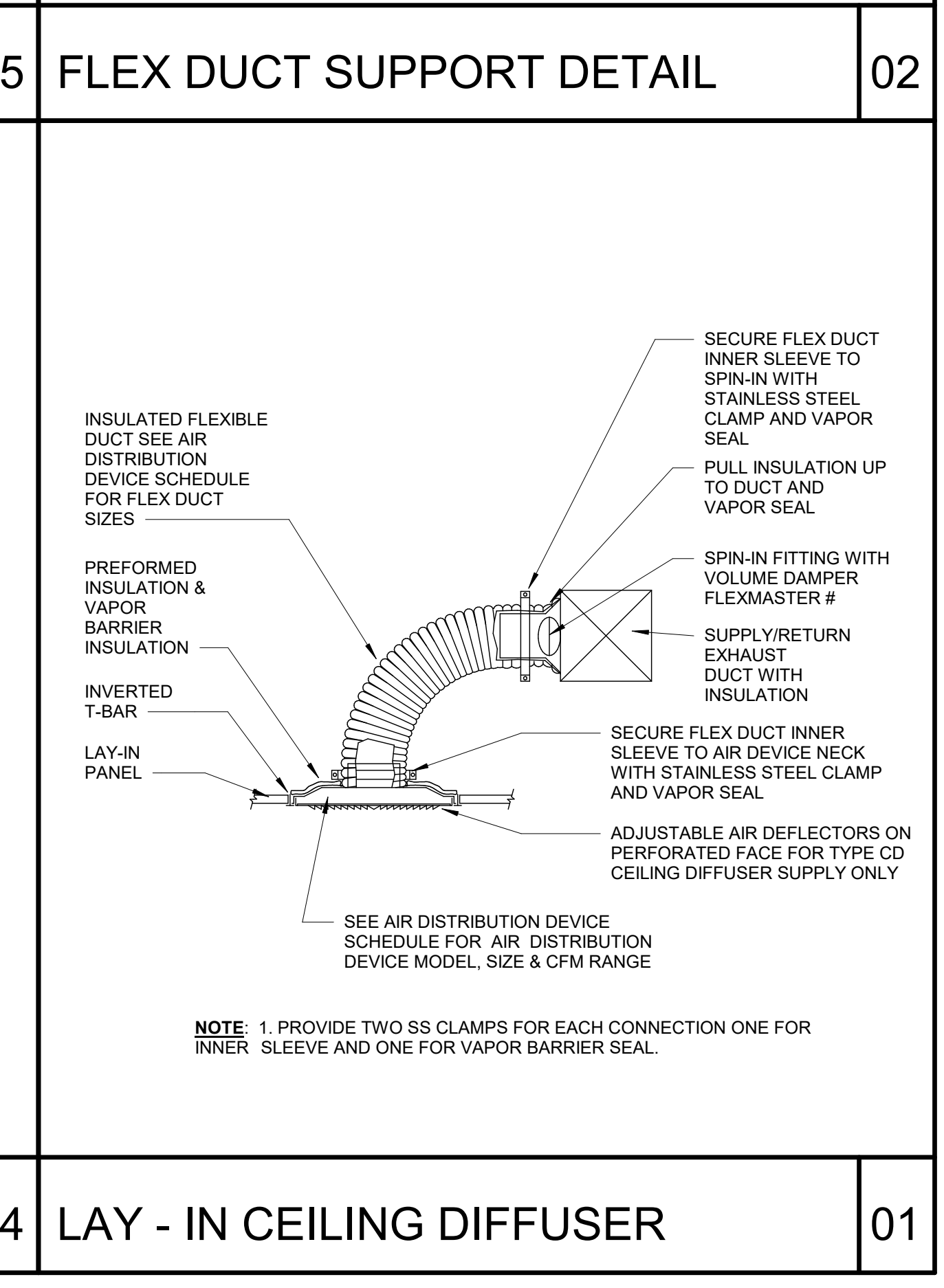
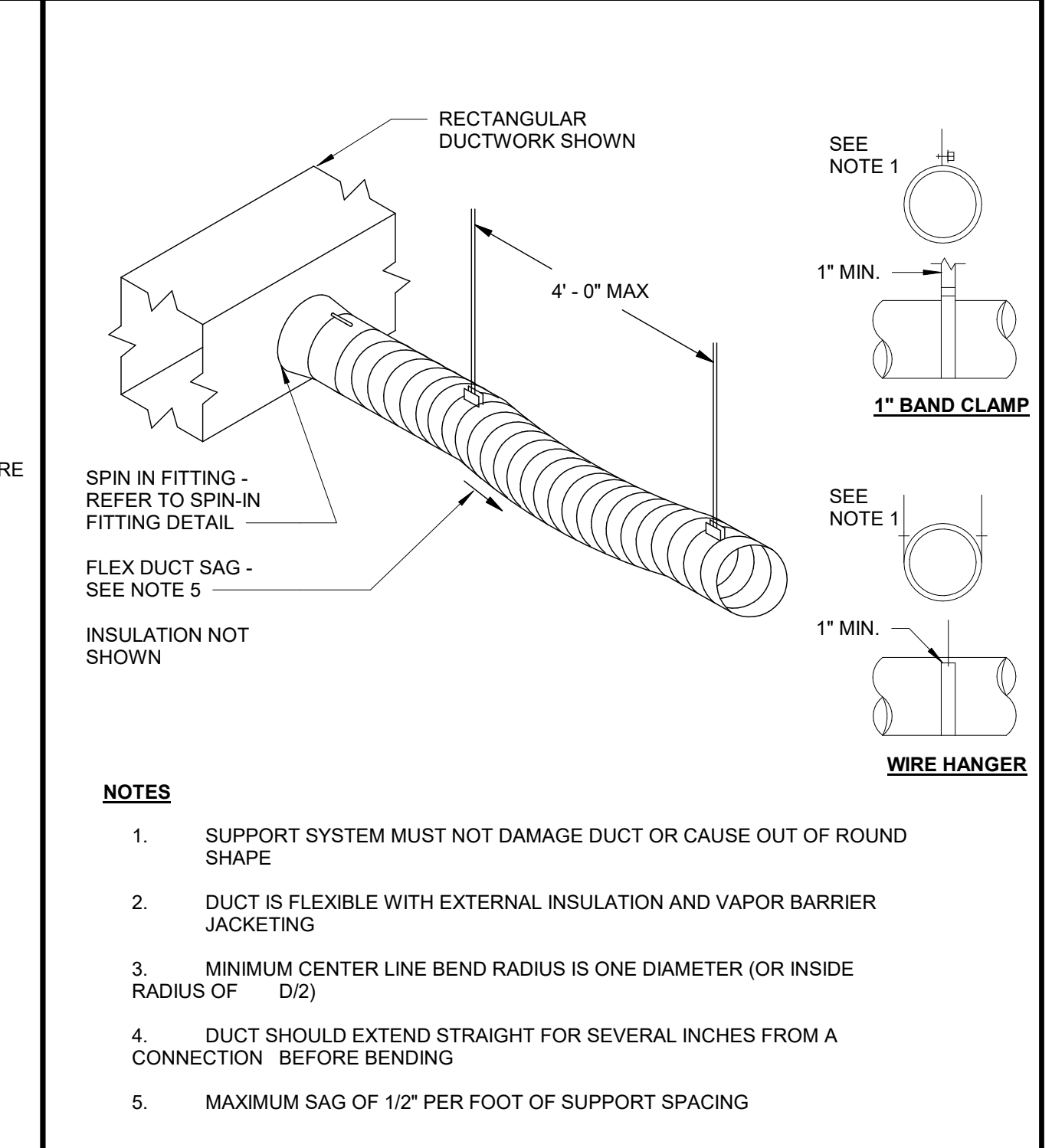

LAY - IN CEILING DIFFUSER 01

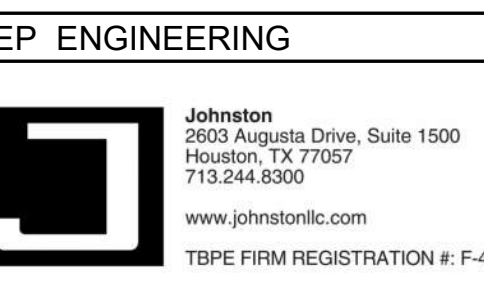
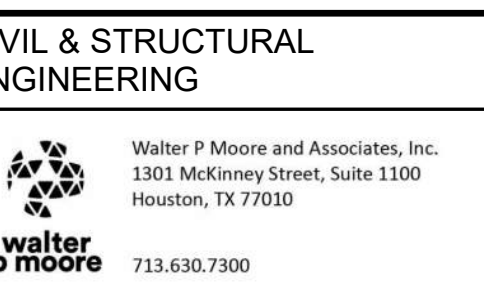

PROJECT TITLE:  
UTPB - VALET & DRIVEWAY RENOVATION

PLAN KEY:

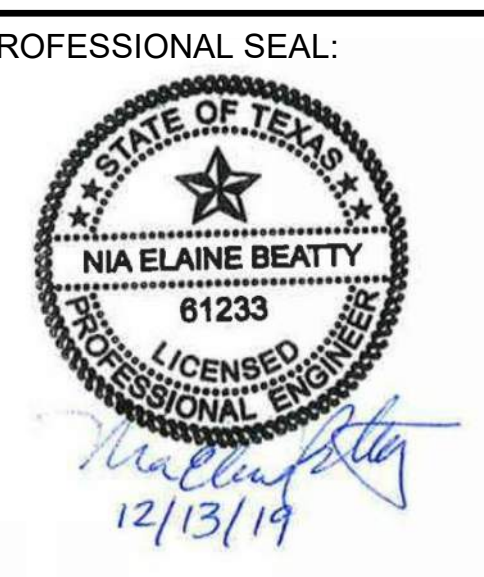

PROJECT SUBMISSION:  
ADDENDUM #01

DATE: 2019 12 16

NO.	REVISION/ISSUE	YYYY MM DD
1	ADDENDUM #01	12/16/2019

PROJECT NO: 19-00032-00  
DRAWN BY: Author

SHEET TITLE:  
MECHANICAL SCHEDULES, CONTROLS, AND DETAILS

SHEET:  
M0.01



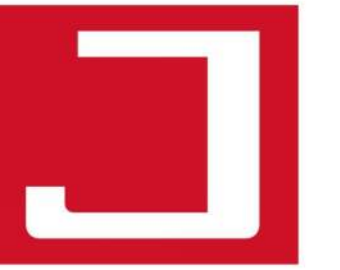

JOHNSTON

2803 Augusta Drive, Suite 1500  
Houston, TX 77057  
713.244.8300  
www.johnstonllc.com

CLIENT:



The University of Texas  
Health Science Center at Houston

CIVIL & STRUCTURAL  
ENGINEERING

Walter P. Moore and Associates, Inc.  
1301 McKinney Street, Suite 1100  
Houston, TX 77002  
713.630.7300

MEP ENGINEERING

Johnston  
2803 Augusta Drive, Suite 1500  
Houston, TX 77057  
713.244.8300  
www.johnstonllc.com  
TPEE FIRM REGISTRATION #: F-421

PROJECT TITLE:

UTPB - VALET &  
DRIVEWAY  
RENOVATION

PLAN KEY:

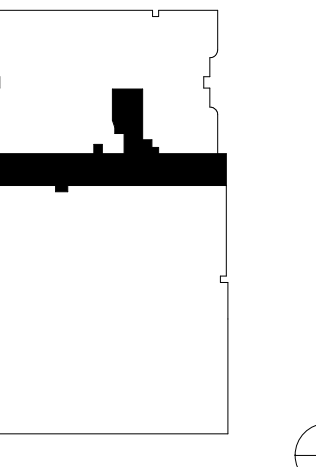

PROFESSIONAL SEAL:



PROJECT SUBMISSION:

DATE: 2019 12 16

NO. REVISION/ISSUE YYYY MM DD

1 ADDENDUM #01 12/16/2019

PROJECT NO: 19-00032-00

DRAWN BY: Author

SHEET TITLE:

MECHANICAL  
DUCTWORK PLAN -  
LEVEL 1

SHEET:

M2.01

MECHANICAL GENERAL NOTES

- DRAWINGS ARE PROVIDED TO SHOW INTENT OF THE SYSTEM LAYOUT AND ARE DIAGRAMMATIC ONLY.
- CONTRACTOR SHALL FIELD VERIFY EXISTING CONDITIONS AND LOCATION OF EXISTING EQUIPMENT, DUCTWORKS, DIFFUSERS, ETC. TO REMAIN BEFORE COMENCING ANY WORKS.
- CONTRACTOR SHALL COORDINATE RENOVATION WORK WITH OWNER AND WITH OTHER CONTRACTORS.
- CLEAN ALL CONSTRUCTION DEBRIS AFTER ALL EQUIPMENT, DUCTWORKS, DIFFUSERS, ETC HAVE BEEN INSTALLED. CONTRACTOR SHALL PROTECT OWNER PROPERTIES FROM DAMAGES AND DUSTS.
- THE AIR SYSTEM, EACH AIR DISTRIBUTION DEVICES SHALL BE ADJUSTED TO WITHIN 10% OF DESIGN AIR FLOW.
- PROVIDE SPACE FOR OPERATION AND MAINTENANCE AS RECOMMENDED BY THE MANUFACTURER.
- DUCTWORK INSULATION REQUIREMENTS SHALL MEET OR EXCEED ALL IECC MINIMUM.
- ALL 2'x2' SUPPLY AIR GRILLES ARE FOUR-WAY THROW PATTERN UNLESS OTHERWISE NOTED.
- AT ALL SUPPLY AIR DUCTWORK PROVIDE TURNING VANES OR FULL-RADIUS ELBOWS AT ALL TURNS. PROVIDE DUCT TAKE-OFFS WITH BALANCING DAMPERS.
- SEAL AROUND DUCTWORK AIR TIGHT AT ALL WALL PENETRATION.
- COORDINATE AIR DEVICE COLOR WITH ARCHITECT.
- ALL HVAC EQUIPMENT AND CONTROLS SHALL BE LABELED FOR IDENTIFICATION. LABELING/IDENTIFICATION SHALL BE LEGIBLE AND MECHANICALLY SECURED TO THE EQUIPMENT WITH NON-CORRODING FASTENERS.
- CONTRACTOR SHALL PREPARE AND INSTALL ALL NEW MCHANICAL EQUIPMENT AND DUCTWORK INSTALLATION BEFORE SWITCHING INTO NEW SYSTEM.

MECHANICAL KEYNOTES

(KEYNOTES SHOWN FOR THIS SPECIFIC SHEET ONLY)

- M05 INSTALL NEW VAV. RE-BALANCE EXISTING AHU TO ACCOMMODATE NEW VAV BOX. REF: SCHEDULE.
- M07 BALANCE EXHAUST RISER.
- M08 TAKE PRE-READINGS AND REBALANCE-TERMINAL UNIT. AFTER SETTING AIRFLOW AT DIFFUSER IN CORRIDOR. RELOCATE THERMOSTAT IF NECESSARY
- M09 RELOCATE EXISTING DIFFUSER TO NEW LOCATION, EXTEND DUCT AS NECESSARY. REF: M2.01.
- M12 INSTALL SMOKE DAMPER INTO EXISTING DUCTWORK.

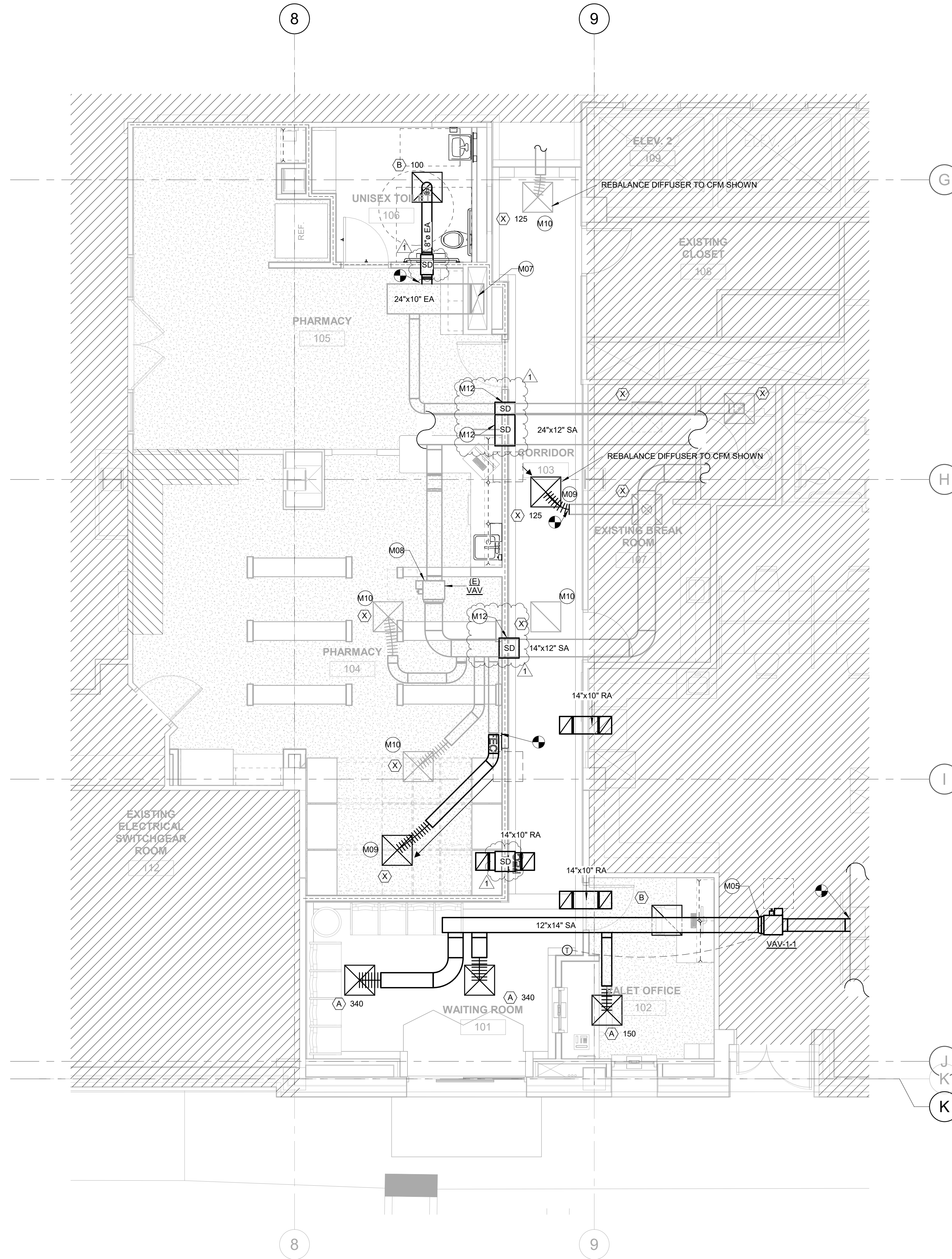

1 MECHANICAL ENTRY LEVEL  
1/4" = 1'-0"





**JOHNSTON**

2803 Augusta Drive, Suite 1500  
Houston, TX 77057  
713.244.8200  
www.johnstonllc.com

CLIENT:



The University of Texas  
Health Science Center at Houston

CIVIL & STRUCTURAL  
ENGINEERING

Walter P Moore and Associates, Inc.  
1301 McKinney Street, Suite 1100  
Houston, TX 77002  
713.630.7300

MEP ENGINEERING

Johnston  
2803 Augusta Drive, Suite 1500  
Houston, TX 77057  
713.244.8200  
www.johnstonllc.com  
TPE FIRM REGISTRATION #: F-421

PROJECT TITLE:

**UTPB - VALET &  
DRIVEWAY  
RENOVATION**

PLAN KEY:

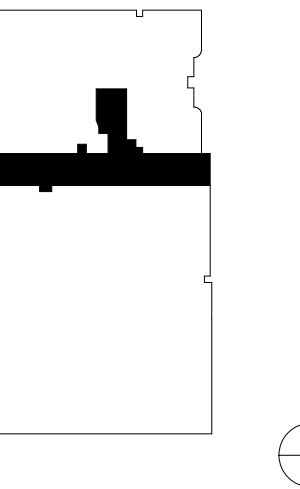

PROFESSIONAL SEAL:

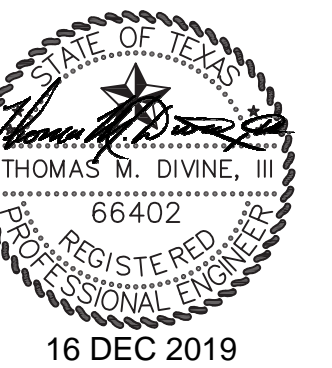

PROJECT SUBMISSION:

DATE: 2019 12 16

NO. REVISION/ISSUE YYYY MM DD

1 ADDENDUM #01 12/16/2019

PROJECT NO: 19-00032-00

DRAWN BY: Author

SHEET TITLE:  
**ELECTRICAL SITE  
PLAN**

SHEET:

**E1.01**

**ELECTRICAL KEYNOTES**  
(KEYNOTES SHOWN FOR THIS SPECIFIC SHEET ONLY)

- L02 LIGHT FIXTURES ARE EXISTING TO REMAIN UNLESS NOTED OTHERWISE. (TYPICAL)
- L03 VERIFY THAT A PORTION OF THE CANOPY LIGHTS ARE SERVED FROM AN EMERGENCY CIRCUIT. IF NONE ARE SERVED FROM AN EMERGENCY CIRCUIT(S), PROVIDE NEW EMERGENCY CIRCUIT(S) AS REQUIRED TO SERVE CANOPY LIGHTS, AND SERVE INDICATED FIXTURES FROM EMERGENCY CIRCUIT(S). NEW LIGHT FIXTURES ARE TO BE REPLACED IN LOCATION CURRENTLY OCCUPIED BY EXISTING FIXTURES.
- L08 REPAIR, PATCH AND PAINT CANOPY TO RESTORE TO ORIGINAL CONDITIONS.

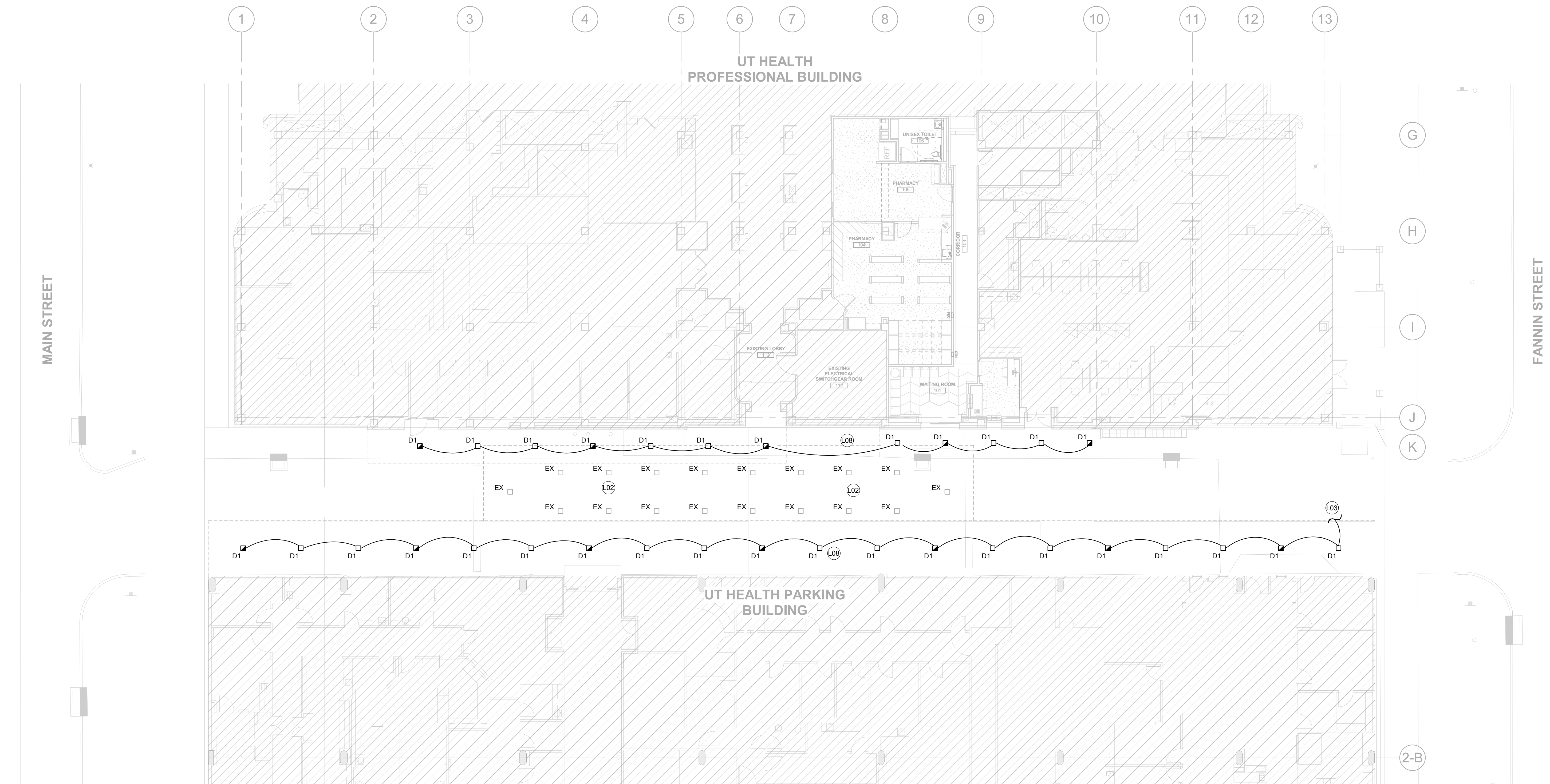

**1 ELECTRICAL SITE PLAN**  
3/32" = 1'-0"





**JOHNSTON**

2803 Augusta Drive, Suite 1500  
Houston, TX 77057  
713.244.8300  
www.johnstonllc.com

CLIENT:



CIVIL & STRUCTURAL  
ENGINEERING

Walter P Moore and Associates, Inc.  
1301 McKinney Street, Suite 1100  
Houston, TX 77002  
713.630.7300

MEP ENGINEERING

Johnston  
2803 Augusta Drive, Suite 1500  
Houston, TX 77057  
713.244.8300  
www.johnstonllc.com  
TPE FIRM REGISTRATION # F-421

PROJECT TITLE:

**UTPB - VALET &  
DRIVEWAY  
RENOVATION**

PLAN KEY:

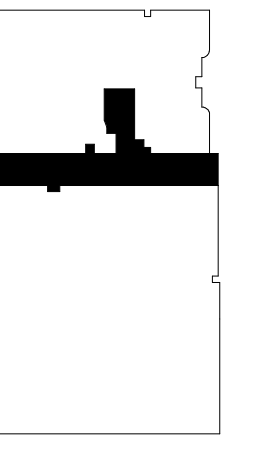

PROFESSIONAL SEAL:



PROJECT SUBMISSION

DATE: 2019 12 16

NO. REVISION/ISSUE YYYY MM DD

1 ADDENDUM #01 12/16/2019

PROJECT NO: 19-00032-00

DRAWN BY: Author

SHEET TITLE:

**ELECTRICAL  
LIGHTING PLAN -  
LEVEL 1**

SHEET:

**E2.01**

**ELECTRICAL KEYNOTES**  
(KEYNOTES SHOWN FOR THIS SPECIFIC SHEET ONLY)

- L04 MATCH EXISTING EXTERIOR DOWNLIGHT AND CONNECT TO EMERGENCY CIRCUIT.
- L05 CONNECT TO EXISTING EMERGENCY CIRCUIT SERVING LIGHT FIXTURES IN THIS AREA
- L06 CONNECT TO EXISTING NORMAL POWER CIRCUIT SERVING LIGHT FIXTURES IN THIS AREA

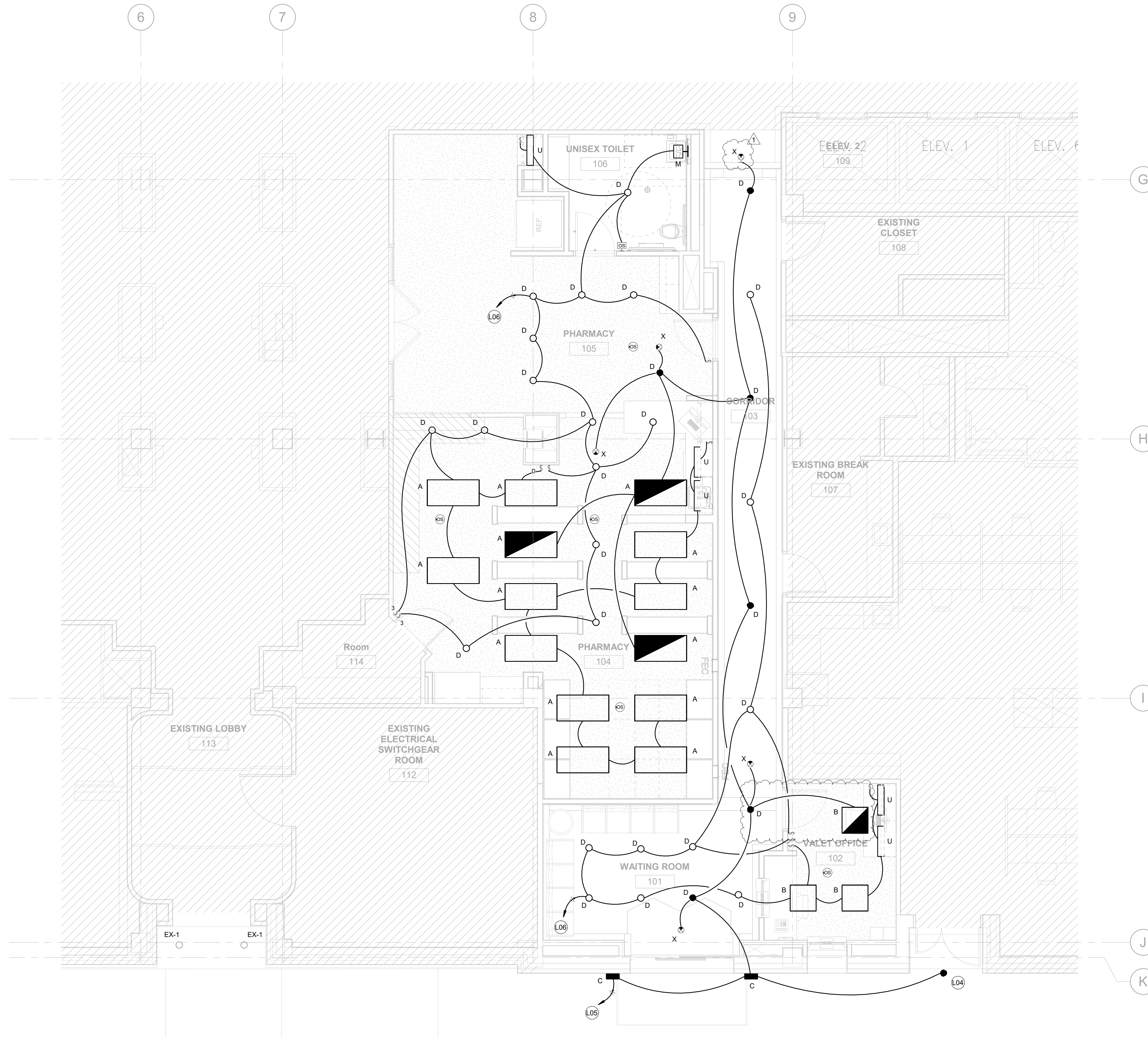

**1** ELECTRICAL LIGHTING PLAN - LEVEL 1  
1/4" = 1'-0"





**JOHNSTON**  
 2803 Augusta Drive, Suite 1500  
 Houston, TX 77057  
 713.244.8300  
 www.johnstonllc.com

CLIENT:



CIVIL & STRUCTURAL  
 ENGINEERING

Walter P Moore and Associates, Inc.  
 1301 McKinney Street, Suite 1100  
 Houston, TX 77002  
 713.630.7300

MEP ENGINEERING

Johnston  
 2803 Augusta Drive, Suite 1500  
 Houston, TX 77057  
 713.244.8300  
 www.johnstonllc.com  
 TPEI FIRM REGISTRATION # F-421

PROJECT TITLE:

**UTPB - VALET &  
 DRIVEWAY  
 RENOVATION**

PLAN KEY:

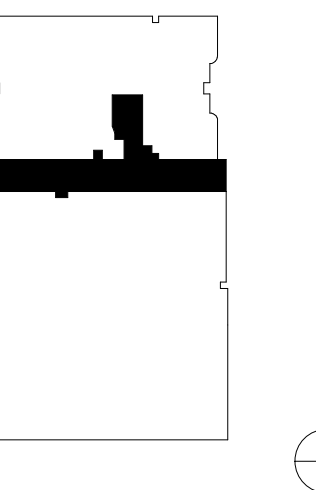

PROFESSIONAL SEAL:



PROJECT SUBMISSION:

DATE: 2019 12 16

NO. REVISION/ISSUE YYYY MM DD

1 ADDENDUM #01 12/16/2019

PROJECT NO: 19-00032-00

DRAWN BY Author

SHEET TITLE:

**ELECTRICAL  
 POWER PLAN -  
 LEVEL 1**

SHEET:

**E3.01**

**ELECTRICAL KEYNOTES**  
 (KEYNOTES SHOWN FOR THIS SPECIFIC SHEET ONLY)

- E02 VOICE/DATA OUTLET. INSTALL OUTLET BOX. PROVIDE 1" CONDUIT WITH PULL STRING AND GROMMET TO LOCATION ABOVE ACCESSIBLE CEILING
- E03 VERIFY EXISTING RECEPTACLE AND DATA OUTLET AT APPROXIMATELY 72" AFF. OTHERWISE, PROVIDE RECEPTACLE AND DATA OUTLET AT 72" AFF. CONNECT RECEPTACLE TO CIRCUIT CURRENTLY SERVING TELEVISION.



**1 ELECTRICAL POWER PLAN - LEVEL 1**  
 1/4" = 1'-0"





**JOHNSTON**

2803 Augusta Drive, Suite 1500  
Houston, TX 77057  
713.244.8300  
www.johnstonllc.com

CLIENT:



The University of Texas  
Health Science Center at Houston

CIVIL & STRUCTURAL  
ENGINEERING

Walter P Moore and Associates, Inc.  
1301 McKinney Street, Suite 1100  
Houston, TX 77002  
713.630.7300  
www.walterpmoore.com

MEP ENGINEERING

Johnston  
2803 Augusta Drive, Suite 1500  
Houston, TX 77057  
713.244.8300  
www.johnstonllc.com  
TPE FIRM REGISTRATION # F-421

PROJECT TITLE:

**UTPB - VALET &  
DRIVEWAY  
RENOVATION**

PLAN KEY:

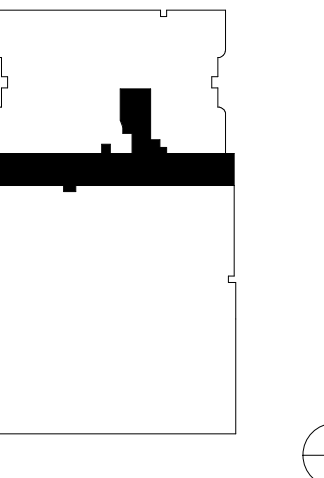

PROFESSIONAL SEAL:



PROJECT SUBMISSION:

DATE: 2019 12 16

NO. REVISION/ISSUE YYYY MM DD

1 ADDENDUM #01 12/16/2019

PROJECT NO: 19-00032-00

DRAWN BY Author

SHEET TITLE:  
**ELECTRICAL FIRE  
ALARM PLAN -  
LEVEL 1**

SHEET:

**E5.01**



**1** ELECTRICAL FIRE ALARM PLAN - LEVEL 1  
1/4" = 1'-0"